

U.0180.0.4/engelberger/3000/01/2010

LAUFEN

bathrooms



www.laufen.com

LAUFEN

modernaplus



04
The designers
Die Designer
Les designers
I designer

06
modernaplust in the room
modernaplust im Raum
modernaplust dans la pièce
modernaplust nello spazio

10
Washbasins
Waschtische
Lavabos
Lavabi

14
WCs and bidets
WCs und Bidets
WC et bidets
Vasi e bidet

16
Bathtubs and shower trays
Badewannen und Duschen
Baignoires et douches
Vasche e docce

modernaplust

The bathroom classic –
a new interpretation

Der Badeklassiker – neu interpretiert
Le classique de la salle de bains réinterprété
La linea classica da bagno reinterpretata

18
Furniture
Möbel
Mobilier
Mobili

30
Faucets
Armaturen
Robinetterie
Rubinetti

modernaplust – Timelessly new

Zeitlos neu
Intemporel
La rinascita dell'intramontabile



The central form of modernaplust by LAUFEN is the trapezium. The series was developed by Peter Wirz, Process Design. This company is based in Zurich, Lucerne and Taipei and has received many awards for its work. It specialises in product design and has already collaborated with LAUFEN on several occasions.

The matching furniture hails from the Polka product design studio in Vienna. Using unusual perspectives, Monica Singer and Marie Rahm of Polka seek to reveal beauty in the everyday, thus surprising the beholder. In addition to their own work, Polka also collaborates on projects for other international renown companies.

Winterthur-based designer Sven Adolph of Momentum Design has designed the faucets for the SimilarGroup. The result: simple, everyday faucets that are unusual at the same time.

Zentrale Form von modernaplust by LAUFEN ist das Trapez. Entwickelt wurde sie von Peter Wirz, Process Design. Das mehrfach für seine Arbeiten ausgezeichnete Unternehmen mit Sitz in Zürich, Luzern und Taipei ist spezialisiert auf Produktdesign und hat schon mehrfach mit LAUFEN zusammengearbeitet.

Die passenden Möbel stammen aus dem Wiener Atelier für Produktdesign, Polka. Durch ungewohnte Perspektiven versuchen Monica Singer und Marie Rahm von Polka, das Schöne im Alltäglichen sichtbar zu machen und so den Betrachter zu überraschen. Neben eigenen Arbeiten realisiert Polka auch Projekte für weitere international renommierte Firmen.

Der in Winterthur tätige Designer Sven Adolph, Momentum Design, hat die Armaturen für SimilarGroup gestaltet. Das Resultat: Armaturen, die schlicht, alltagsnah und ungewöhnlich zugleich sind.

La forme centrale de modernaplust by LAUFEN est le trapèze. Cette ligne a été conçue par Peter Wirz, Process Design. L'entreprise, maintes fois récompensée pour ses travaux et implantée à Zurich, Lucerne et Taipei, est spécialisée dans le design de produits et a déjà collaboré à plusieurs reprises avec LAUFEN.

Les meubles adaptés à la gamme viennent de l'atelier viennois de design de produits Polka. En intégrant des perspectives inhabituelles, Monica Singer et Marie Rahm, de Polka, tentent de sublimer le quotidien et de surprendre l'observateur. Outre leurs propres œuvres, Polka réalise également des projets pour d'autres sociétés de renommée internationale.

Le designer Sven Adolph, qui travaille à Winterthur chez Momentum Design, a conçu les robinetteries pour SimilarGroup. Le résultat: des robinetteries qui sont à la fois sobres, utilitaires et surprenantes.

La forma centrale di modernaplust by LAUFEN è il trapezio. È stata ideata da Peter Wirz, Process Design. L'azienda con sede a Zurigo, Lucerna e Taipei, è stata più volte premiata per i suoi lavori, è specializzata in prodotti di design e ha già collaborato con LAUFEN varie volte.

I mobili abbinabili provengono dall'atelier viennese di product design Polka. Con prospettive insolite Monica Singer e Marie Rahm di Polka cercano di dare visibilità alla bellezza nella quotidianità e di sorprendere in questo modo l'osservatore. Oltre alle proprie opere, Polka realizza anche progetti per rinomate ditte di fama internazionale.

Il designer Sven Adolph, che lavora a Winterthur presso Momentum Design, ha realizzato gli articoli di rubinetteria per SimilarGroup. Il risultato: rubinetti che sono al contempo semplici, pratici nella quotidianità e sorprendenti.



Bewährtes neu interpretiert
L'éprouvé réinventé
Una soluzione collaudata e reinterpretata

modernaplus – A new interpretation
of the tried and tested



Harmony as a concept

modernaplust is an extensive, high-quality range. All the individual parts complement one another to give a whole that is both aesthetically and functionally pleasing.

The range comprises everything from ceramic products to matching furniture and includes bathtubs and shower trays, faucets and practical ceramic shelves, thus achieving a harmonious arrangement from a single source.

Harmonie als Konzept

modernaplust ist ein qualitativ hochwertiges Komplettprogramm. Sämtliche Einzelteile ergänzen sich zu einem ästhetisch und funktional ansprechenden Ganzen. Das Programm umfasst von der Keramik über das passende Mobiliar auch Bade- und Duschwannen, Armaturen sowie praktische Ablagen aus Keramik und erlaubt so eine harmonische Einrichtung aus einem Guss.

L'harmonie en tant que concept

modernaplust est un programme complet de grande qualité. Tous les éléments qui le composent se complètent pour former un ensemble alliant esthétique et fonctionnalité. Le programme englobe la céramique et le mobilier adéquat, de même que les baignoires et receveurs de douche, les robinetteries ainsi que les étagères pratiques en céramique, ce qui permet un aménagement fluide et harmonieux.

L'armonia come principio

modernaplust è un programma completo di alto livello qualitativo. Tutti i singoli elementi si combinano in un insieme funzionale e di grande impatto estetico. Il programma, che comprende ceramiche, mobili abbinabili, piatti doccia e vasche da bagno, rubinetti e pratici scomparti in ceramica, consente di allestire il bagno con uno stile armonioso ed uniforme.



Diversity in style variations

The elementary geometric shape of the washbasin is the trapezium, which gently opens up towards the user.

The modernplus washbasin comes in different sizes and style variations and is easily combined with other items. So a suitable solution can be found for every need.

Vielfalt in Varianten

Geometrische Grundform des Waschbeckens ist das Trapez, das sich zum Benutzer hin sanft öffnet.

Das modernplus-Waschbecken gibt es in verschiedenen Grössen und Varianten und ist einfach kombinierbar. So findet sich für jedes Bedürfnis die passende Antwort.

De la diversité dans les variations

La forme géométrique de base du lavabo est le trapèze, qui se révèle en douceur à l'utilisateur. Le lavabo modernplus existe dans différentes tailles et variantes, et se combine facilement. A chaque besoin correspond ainsi une solution.

Diversità nelle varianti

La forma geometrica di base del lavandino, il trapezio, si rivela delicatamente all'utilizzatore. Il lavamani modernplus è disponibile in diverse misure e varianti ed è facile da abbinare. Una soluzione su misura per ogni esigenza!

Practical – the hand washbasin leaves room for other things
 Praktisch – das Handwaschbecken lässt Platz für anderes
 Pratique – le lave-mains laisse la place à d'autres éléments
 Pratico – il lavamani lascia molto spazio ad altri elementi



Pure – simple and classical
 Pur – einfach und klassisch
 Pur – simple et classique
 Puro – semplice e classico



Discreet – with ceramic siphon cover
 Diskret – mit keramischer Siphonverkleidung
 Discret – avec cache-siphon en céramique
 Discreto – con il copri-sifone in ceramica



Stable – with an elegant pedestal
 Standfest – mit eleganter Säule
 Stable – avec colonne élégante
 Stabile – con un'elegante colonna





Combine according to your mood: thanks to its simple elegance the washbasin meets every requirement. And will fit in any corner as the situation demands.

Kombinieren nach Lust und Laune: Dank seiner schlichten Eleganz passt sich das Waschbecken jedem Wunsch an. Und wenn es die Verhältnisse verlangen, auch jeder Ecke.

A combiner à l'envi: grâce à son élégance sobre, le lavabo ne laisse aucun souhait inassouvi. Même si l'espace l'exige.

Combinazioni a piacimento: grazie alla sua semplice eleganza il lavamani si adatta ad ogni esigenza. E all'occorrenza anche ad ogni angolo.



Built-in washbasin
Einbauwaschtisch von unten
Lavabo à encastrer par-dessous
Lavabo da incasso sottopiano



Corner washbasin
Eckwaschtisch
Lavabo d'angle
Lavabo angolare



Vanity unit
Möbelwaschtisch
Lavabo à poser sur meuble
Lavabo per mobile

Beautifully economical

WC and bidet come in three style variations: traditional and established, in an updated design and with a completely new look. Whichever one you decide on: all three combine harmoniously with the modernaplust world of shapes.

And because the environment is important to us, we have designed the range so that it is not just beautiful and comfortable – it is also particularly economical when it comes to water consumption. Where previously 6 litres were needed, the two new models manage with just 4.5 and 3 litres respectively, saving precious resources and caring for the environment.

Schön sparsam

WC und Bidet gibt es in drei Varianten: traditionell und bewährt, im aktualisierten Design und im komplett neuen Kleid. Ganz gleich, für welches man sich entscheidet: Alle drei verbinden sich harmonisch mit der Formenwelt von modernaplust. Und weil uns die Umwelt wichtig ist, haben wir sie so gestaltet, dass sie nicht nur schön und bequem, sondern besonders sparsam im Wasserverbrauch sind. Wozu es bisher 6 Liter brauchte, das schaffen die beiden neuen Modelle auch mit 4,5 bzw. 3 Litern. Das schont kostbare Ressourcen und trägt zur Umwelt Sorge.

Jolis et sobres

WC et bidet existent dans trois variantes: traditionnelle et éprouvée, dans un design actualisé et dans un look complètement nouveau. Quelle que soit la décision prise, ces trois déclinaisons s'harmonisent avec le monde des formes de modernaplust. Et parce que l'environnement nous tient à cœur, nous avons conçu ces éléments de telle façon qu'ils soient non seulement beaux et confortables, mais aussi particulièrement sobres dans leur consommation d'eau. Là où on a eu besoin de 6 litres d'eau, les deux modèles se contentent de 4,5 et 3 litres. Ils ménagent ainsi les précieuses ressources et veillent à la préservation de l'environnement.

Belli e con un occhio al consumo

Vaso e bidet sono disponibili in tre varianti: nella versione tradizionale e collaudata, in un design modernizzato e in una veste del tutto nuova. Qualunque sia la scelta personale, tutti e tre si declinano armoniosamente con il mondo delle forme di modernaplust. E poiché ci teniamo al rispetto dell'ambiente, abbiamo concepito questi elementi in modo tale che siano, non solo belli e comodi, ma anche a basso consumo idrico. Ove finora si consumavano 6 litri d'acqua, i due nuovi modelli si limitano ad utilizzarne 4,5 o 3 litri. In questo modo salvaguardiamo le preziose risorse e rispettiamo l'ambiente.



Fashionable technology and design: *modernaplust*
 Technik und Design auf der Höhe der Zeit: *modernaplust*
 Technique et design à hauteur du temps: *modernaplust*
 Tecnica e design all'altezza del tempo: *modernaplust*



Synthesising the tried and tested with the new: *moderna R*
 Synthese von Bewährtem mit Neuem: *moderna R*
 La synthèse de l'éprouvé et du nouveau: *moderna R*
 Una sintesi tra il collaudato e il nuovo: *moderna R*



Popular and proven basic shape
 Beliebte und bewährte Grundform
 Forme de base appréciée et éprouvée
 La forma di base amata e collaudata



Simply inviting: baths and showers

With their simple, clear lines, the bathtubs and shower trays blend seamlessly into the overall concept of modernaplust and provide the ideal solution for all options.

Of course, modernaplust can also be combined with various large, sanitary acrylic or steel bathtubs and shower trays from the LAUFEN solutions range. Particularly elegant: the flat shower trays.



Steel bathtub
Stahlwanne
Baignoire en
acier
Vasca in
acciaio

Acrylic bathtub
from the
LAUFEN
solutions range
Acrylwanne aus
dem Sortiment
LAUFEN
solutions
Baignoire en
acrylique de
l'assortiment
LAUFEN
solutions
Vasca in acrilico
della gamma
LAUFEN
solutions



Einfach einladend: Bäder und Duschen

Mit ihren einfachen und klaren Linien fügen sich die Bade- und Duschwannen nahtlos in das Gesamtkonzept von modernaplust ein und bieten für alle Optionen die ideale Lösung. Selbstverständlich lässt sich modernaplust auch mit verschiedenen grossen Bade- und Duschwannen aus Sanitäracryl des Sortiments LAUFEN solutions oder aus Stahl kombinieren. Besonders elegant: die flachen Duschwannen.

Tout simplement accueillantes: baignoires et douches

Avec leurs lignes simples et claires, les receveurs de douche et les baignoires se fondent dans le concept global de modernaplust et constituent la solution idéale quelle que soit l'option.

Bien entendu, modernaplust peut être combinée à différents receveurs de douche et baignoires en acrylique sanitaire ou en acier de l'assortiment LAUFEN solutions. Particulièrement élégants: les receveurs de douche plats.

Semplicemente invitanti: bagni e docce

Con le loro linee semplici e pulite le vasche da bagno e i piatti doccia si integrano perfettamente nell'insieme di modernaplust ed offrono la soluzione ideale per tutte le opzioni.

Naturalmente modernaplust può essere combinata anche con piatti doccia e vasche da bagno di diverse misure in acrilico sanitario o in acciaio della gamma LAUFEN solutions. Particolarmente eleganti: i piatti doccia bassi.



A system for storage

The modular furniture system complements the modernaplust ceramics perfectly. It provides plenty of space where there is not much room and will go well with a great variety of colour schemes. Because life is colourful – even in the bathroom.

Aufbewahrung mit System

Das modulare Möbelsystem ergänzt die Keramik von modernaplust perfekt. Es bietet viel Platz auf wenig Raum und lässt sich an verschiedenste Farbgebungen anpassen. Denn das Leben ist bunt – auch im Bad.

Rangement bien pensé

Le système de meubles modulaire complète à la perfection la céramique de modernaplust. Il offre beaucoup de place sur peu d'espace et peut être combiné aux coloris les plus divers.

Ordine ben studiato

Il sistema di mobili modulare completa perfettamente la ceramica di modernaplust. Offre molto posto in poco spazio e si combina con le più svariate tonalità di colore. Infatti, la vita è variopinta, anche nel bagno.



Everything in its place ...

... especially when it is so beautiful. The versatile complementary furniture leaves nothing to be desired and also ensures that everything in the bathroom is sorted and within easy reach.

Well arranged and practical thanks to three glass shelves, drawer and pull-out box

Übersichtlich und praktisch dank drei Glasfachböden, Schublade und herausnehmbarer Box

Clair et pratique grâce à trois étagères en verre, au tiroir et au box amovible

Pratico e funzionale grazie a tre ripiani in vetro, cassetto e contenitore estraibile



Ordnung muss sein ...

... vor allem, wenn sie so schön ist. Die vielseitigen Ergänzungsmöbel lassen keine Wünsche offen und sorgen auch im Bad dafür, dass alles im Griff und in Griffweite bleibt.

Ranger les choses ...

... surtout quand c'est beau. Les meubles d'appoint polyvalents combient tous les désirs et veillent à ce que tout reste sous contrôle et à portée de main dans la salle de bains.

L'ordine è necessario ...

... soprattutto se è bello. I versatili elementi di arredo soddisfano tutti i desideri e consentono di avere tutto sotto controllo e a portata di mano.





For all circumstances

You don't like compromises? Neither do we. So modernaplust has a sophisticated solution for small rooms too. From the elegant mirror cabinet with integrated lighting, glass shelves and socket to the washbasin and storage unit: modernaplust creates space even in the smallest corner.



Für alle Fälle

Sie mögen keine Kompromisse? Wir auch nicht. Deshalb bietet modernaplust auch für kleine Räume eine durchdachte Lösung. Vom eleganten Spiegelschrank mit integrierter Leuchte, Glasablagen und Steckdose über das Waschbecken bis zum Aufbewahrungsschrank: modernaplust schafft auch in der kleinsten Ecke Platz.

Pour toutes les situations

Vous n'aimez pas les compromis? Nous non plus. C'est pourquoi modernaplust propose une solution judicieuse également pour les petits espaces. De l'élégante armoire de toilette avec lampe intégrée, étagères en verre et prise de courant à l'armoire de rangement, en passant par le lavabo, modernaplust fait de la place même dans les coins les plus exigus.

Per tutte le situazioni

Non vi piacciono i compromessi? Neppure a noi. Per questo modernaplust offre una soluzione intelligente anche per gli spazi limitati. L'elegante armadietto a specchio con luce integrata, i ripiani in vetro e la presa elettrica, il lavamani e l'armadietto portaoggetti: modernaplust ricava lo spazio anche negli angoli più ristretti.





blue, blau, bleu, blu

red, rot, rouge, rosso



grey, grau, gris, grigio

black, schwarz, noir, nero



natural oak, Eiche Natur, chêne naturel, rovere naturale wenge, wenge, wengé, wenge

Highly individual

The mirror cabinets in three different sizes provide plenty of storage space and ensure that everything is kept neat and tidy. The integrated lighting provides a cosy ambient light through a cut-out in the mirror. The cabinets can be optionally fitted with switches and sockets.

The recessed grips on the modernaplust furniture system create a colourful accent: the panels come in a variety of colours, ensuring a personal note in the bathroom. And because a personality can develop, these panels can easily be replaced to fit with new circumstances.

Ganz individuell

Die Spiegelschränke in drei verschiedenen Grössen bieten viel Platz und sorgen für Übersicht und Ordnung. Durch eine Aussparung im Spiegel sorgt die integrierte Leuchte für behagliches Raumlicht. Wahlweise verfügen die Schränke über Schalter und Steckdosen. Einen farbigen Akzent schaffen die Griffmulden des modernaplust Möbelsystems: Verschiedenfarbige Blenden sorgen für eine persönliche Note im Bad. Und weil sich eine Persönlichkeit entwickeln kann, lassen sie sich jederzeit leicht auswechseln

und den neuen Gegebenheiten anpassen.

Entièrement personnalisé

Les armoires de toilette disponibles dans trois tailles différentes offrent beaucoup de place et veillent à la clarté et à l'ordre à la salle de bains. Au moyen d'un creux dans le miroir, la lampe intégrée assure une lumière d'ambiance agréable. Les armoires disposent au choix de commutateurs et de prises de courant. Les poignées coquilles du système de meubles modernaplust donnent une touche de couleur. Des bandes de

couleur permettent de personnaliser la salle de bains. Et comme une personnalité doit pouvoir s'épanouir, elles peuvent être changées à volonté pour être en phase avec les goûts et les tendances.

Massima individualità

Gli armadietti a specchio in tre diverse misure offrono molto spazio e la possibilità di avere tutto ben in vista e in ordine. La luce integrata in una rientranza nello specchio crea un'accogliente atmosfera. A scelta, gli armadietti possono essere accessoriati con interruttori e prese elettriche.

Le maniglie integrate donano una nota di colore nel sistema di mobili modernaplust: i listelli di diversi colori offrono ampie possibilità di personalizzazione. E per dare spazio alle rinnovate espressioni della personalità, possono essere sostituite in qualunque momento per essere in linea con le nuove preferenze o tendenze.



Inner values

The consciously simple exterior appearance of the furniture with its easy-care surfaces impresses with its ingenious interior. The interiors can be adapted entirely to fit the personal needs of the user. The spacious drawers can be divided up individually, ensuring that everything is kept tidy and easily accessible. An interior drawer is optional for certain vanity units, offering the possibility of an even better use of space. Thanks to 'soft-close technology', all the drawers close gently and securely – almost by themselves.

And anything that does not need to go in a drawer will find a space on the unobtrusive ceramic shelves. These are available in various sizes.

Innere Werte

Die äusserlich bewusst schlicht gehaltenen Möbel mit ihren pflegeleichten Oberflächen überzeugen mit einem raffinierten Innenleben. Dieses lässt sich ganz an die persönlichen Bedürfnisse der Benutzer anpassen. Die grosszügigen, individuell unterteilbaren Auszüge sorgen für Übersicht und erleichtern den Zugriff. Bei einzelnen Modellen ist eine Innenschublade optional für eine noch bessere Raumnutzung verfügbar. Dank «Softclose-Technik» schliessen alle Auszüge fast von alleine, sanft und sicher.

Und was nicht in eine Schublade muss, findet Platz auf den dezenten Keramikablagen. Es gibt sie in verschiedenen Grössen.

Valeurs intérieures

Avec leurs surfaces faciles à nettoyer, ces meubles à l'extérieur résolument sobre convainquent par une vie intérieure faite de raffinement et qui s'adapte aux besoins de l'utilisateur. Les tiroirs généreux dont le contenu se divise en fonction des envies garantissent l'ordre et facilitent l'accès aux accessoires. Un tiroir intérieur s'ajoute en option pour certain modèles,

pour une exploitation de l'espace optimisée. Grâce à la technique «Softclose», tous les tiroirs se ferment presque d'eux-mêmes, doucement et en toute sécurité.

Les accessoires qui ne trouvent pas place dans les tiroirs peuvent être posés sur les discrètes étagères en céramique. Ces dernières existent dans différentes tailles.

I valori interni

Realizzati appositamente con una finitura esterna della massima semplicità e facile da pulire, questi mobili convincono per la loro essenza raffinata, che si

adatta facilmente ai bisogni degli utilizzatori. Gli inserti interni ampi e divisibili in base alle esigenze individuali consentono di tenere tutto ben in vista e a portata di mano. Come optional su certi modelli, si può aggiungere un cassetto interno per sfruttare ancora maggiormente lo spazio. Grazie alla tecnica «softclose» tutti i cassetti estraibili si richiudono da soli in modo delicato e sicuro.

Infine, gli oggetti che non vanno riposti nei cassetti estraibili trovano posto sui discreti ripiani in ceramica, disponibili in diverse misure.



Wherever you go

Applying make-up where the light is best: no problem with the trolley and its integrated cosmetics box with mirror.

Schminken, wo das Licht am besten ist: kein Problem mit dem Trolley und seiner integrierten Kosmetikbox mit Spiegel.

Se maquiller sous la meilleure lumière: pas de problème avec le trolley et sa boîte cosmétique intégrée avec miroir.

Truccarsi con la luce migliore: non è un problema grazie al trolley ed al suo portacosmetici integrato con specchio.



With the trolley, the bathroom becomes flexible; everything is always exactly where you need it. The trolley follows on its rollers to wherever it is needed

Mit dem Trolley wird das Bad flexibel; alles ist stets dort, wo es gebraucht wird. Auf seinen Rollen folgt der Trolley überallhin, wo er gebraucht wird

Avec le trolley, la salle de bains est flexible et tout est à sa place. Grâce à ses roulettes, on le déplace partout où il est indispensable

Con il trolley, il bagno acquista flessibilità e tutto è al proprio posto. Sulle sue rotelle il trolley vi segue ovunque ne abbiate bisogno



The cabinet has a glass shelf and a drawer. Here, too, you can create an individual colour note with an interchangeable lining for the recessed grip

Der Schrank verfügt über ein Glastablar sowie eine Schublade. Selbstverständlich lässt sich auch hier die Griffmulde mit einer auswechselbaren Blende farblich individuell gestalten

L'armoire dispose d'une étagère en verre ainsi que d'un tiroir. Bien entendu, les poignées coquilles peuvent être, là aussi, personnalisées grâce à une bande colorée

L'armadietto è dotato di un ripiano in vetro e di un cassetto. Naturalmente anche in questo caso la maniglia integrata può essere personalizzata grazie al listello intercambiabile





Gleaming perfection

The geometry of the trapezium also provides the basis for the functional aesthetics of the faucets. The convenient handle not only gives the faucets their unmistakable character, it also makes them easier to operate. So you literally have everything to hand.

The washbasin mixers are available in two different sizes so that you can also find the correct one for every washbasin.



Glänzend ergänzt

Die funktionale Ästhetik der Armaturen orientiert sich ebenfalls an der Geometrie des Trapezes. Der handliche Bügel verleiht den Armaturen nicht nur ihren unverwechselbaren Charakter, sondern erleichtert auch die Bedienung. Damit haben Sie buchstäblich alles im Griff.

Damit sich zu jedem Waschtisch auch der passende Waschtischmischer findet, gibt es diesen in zwei verschiedenen Größen.

La brillante en plus

L'esthétique fonctionnelle de la robinetterie s'oriente également sur la géométrie du trapèze. Le levier maniable confère aux robinetteries non seulement leur caractère incomparable, mais facilite également la manipulation. Vous avez ainsi la maîtrise parfaite de tout.

Pour que chaque style de lavabo ait son mitigeur adéquat, deux tailles différentes sont proposées.

Un tocco di splendore

Anche l'estetica funzionale dei rubinetti segue la geometria del trapezio. La staffa manuale, oltre a donare ai rubinetti un aspetto inconfondibile, ne facilita l'uso. In questo modo avete letteralmente la situazione in pugno.

Il miscelatore per lavabo è disponibile in due diverse misure per essere abbinato ad ogni lavabo.





1.



2.



3.



4.

1.
Shower single-lever mixer
Duschenmischer
Mitigeur de douche
Miscelatore per doccia
2.
Bath single-lever mixer
Bademischer
Mitigeur de bain
Miscelatore da bagno
3.
Shower single-lever mixer
Duschenmischer
Mitigeur de douche
Miscelatore per doccia
4.
Roman tub filler
Wannenfüllkombination
Garniture de remplissage
de baignoire
Rubinetteria per vasca

The right temperature – effortlessly: let it flow

For baths and showers too, modernaplust offers stylish, functional faucets for every situation. Let the water flow – and let yourself go.

Lassen Sies fließen

Auch für Bad und Dusche bietet modernaplust formschöne und funktionale Armaturen für jede Situation. Lassen Sie das Wasser fließen – und sich gehen.

Un doigt de légèreté: laissez couler

modernaplust propose également pour la baignoire et la douche des robinetteries fonctionnelles et aux jolies formes pour tous les styles. Laissez l'eau couler – et laissez-vous aller.

Dosare con facilità: fatela scorrere

modernaplust propone anche per il bagno e la doccia rubinetti esteticamente belli e funzionali per qualsiasi ambiente. Fate scorrere l'acqua e lasciatevi andare.

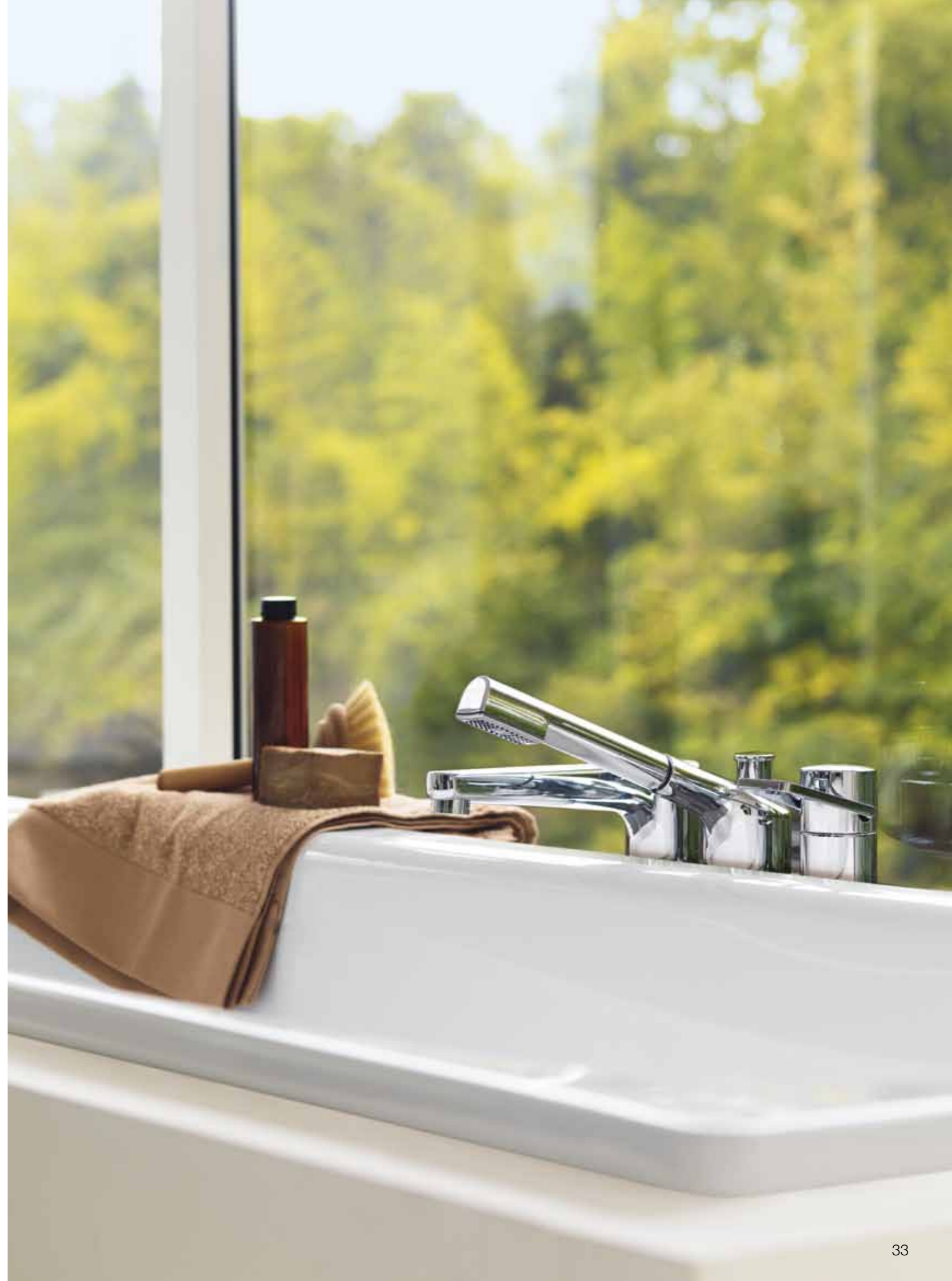

modernaplust by LAUFEN

TECHNICAL INFORMATION

TECHNISCHE INFORMATIONEN
INFORMATIONS TECHNIQUES
INFORMAZIONI TECNICHE

modernaplust



ø1554.1
Small washbasin
Handwaschbecken
Lave-mains
Lavamani

○/●

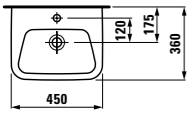
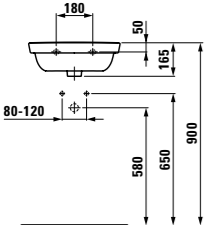
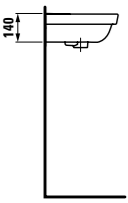
.104 .109 .112

modernaplust



ø1054.1
Washbasin
Waschtisch
Lavabo
Lavabo

○/●/●●●

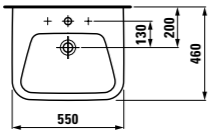
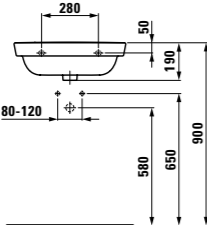
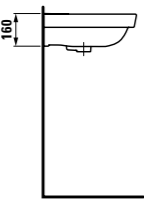
.104 .108 .109 .112

modernaplust



ø1054.1
Washbasin
Waschtisch
Lavabo
Lavabo

○/●/●●●

ø1954.3
Pedestal, ceramic
Säule, Keramik
Colonne, céramique
Colonna, ceramica

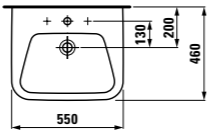
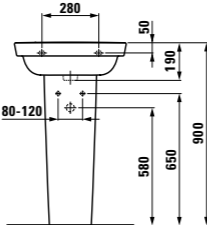
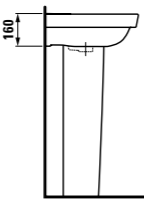
.104 .108 .109 .112

modernaplust



ø1054.1
Washbasin
Waschtisch
Lavabo
Lavabo

○/●/●●●

ø1954.4
Siphon cover, ceramic
Siphonverkleidung, Keramik
Cache-siphon, céramique
Semicolonna, ceramica

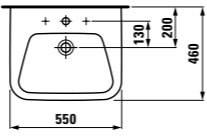
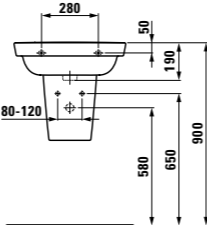
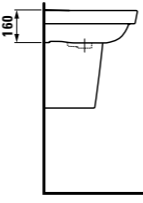
.104 .108 .109 .112

modernaplust



ø1054.2
Washbasin
Waschtisch
Lavabo
Lavabo

○/●/●●●

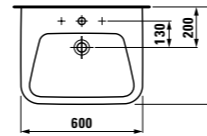
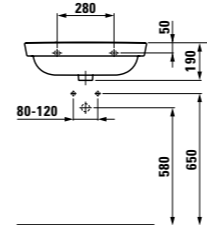
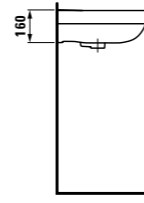
.104 .108 .109 .112

modernaplust



ø1054.2
Washbasin
Waschtisch
Lavabo
Lavabo

○/●/●●●

ø1954.3
Pedestal, ceramic
Säule, Keramik
Colonne, céramique
Colonna, ceramica

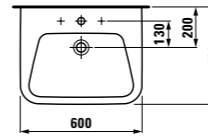
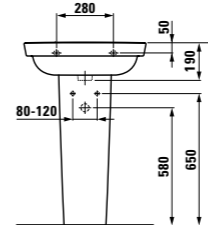
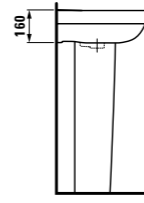
.104 .108 .109 .112

modernaplust



ø1054.2
Washbasin
Waschtisch
Lavabo
Lavabo

○/●/●●●

ø1954.4
Siphon cover, ceramic
Siphonverkleidung, Keramik
Cache-siphon, céramique
Semicolonna, ceramica

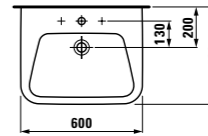
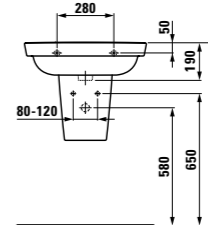
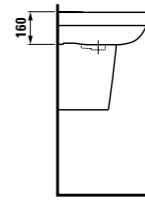
.104 .108 .109 .112

modernaplust



ø1054.3
Washbasin
Waschtisch
Lavabo
Lavabo

○/●/●●●

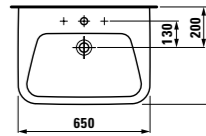
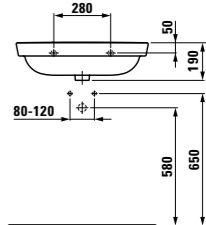
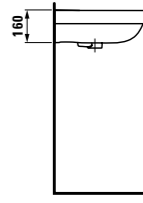
.104 .108 .109 .112

modernaplust



ø1554.1
Small washbasin
Handwaschbecken
Lave-mains
Lavamani

○/●

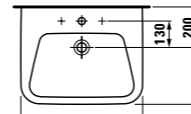
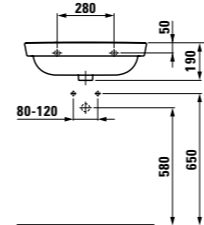
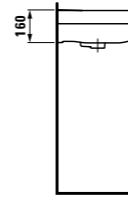
.104 .109 .112

modernaplust



ø1054.1
Washbasin
Waschtisch
Lavabo
Lavabo

○/●/●●●

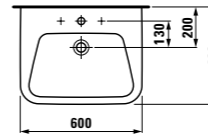
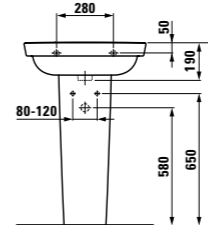
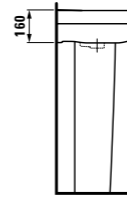
.104 .108 .109 .112

modernaplust



ø1054.1
Washbasin
Waschtisch
Lavabo
Lavabo

○/●/●●●

ø1954.3
Pedestal, ceramic
Säule, Keramik
Colonne, céramique
Colonna, ceramica

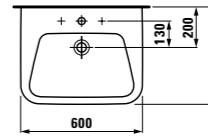
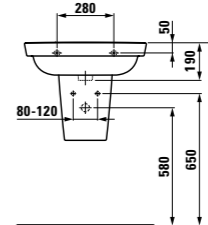
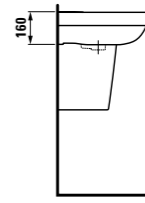
.104 .108 .109 .112

modernaplust



ø1054.1
Washbasin
Waschtisch
Lavabo
Lavabo

○/●/●●●

ø1954.4
Siphon cover, ceramic
Siphonverkleidung, Keramik
Cache-siphon, céramique
Semicolonna, ceramica

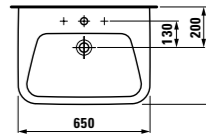
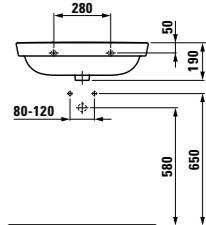
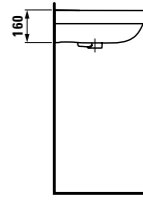



.104 .108 .109 .112

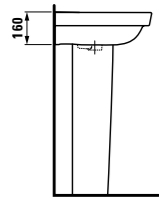
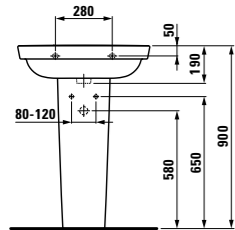
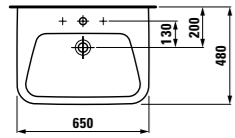

modernaplust
 81054.3
Washbasin
 Waschtisch
 Lavabo
 Lavabo

81954.3
Pedestal, ceramic
 Säule, Keramik
 Colonne, céramique
 Colonna, ceramica



.104 .108 .109 .112



modernaplust
 81054.3
Washbasin
 Waschtisch
 Lavabo
 Lavabo

81954.4
Siphon cover, ceramic
 Siphonverkleidung, Keramik
 Cache-siphon, céramique
 Semicolonna, ceramica

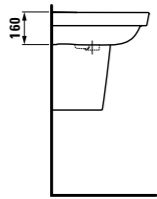
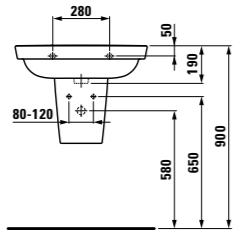
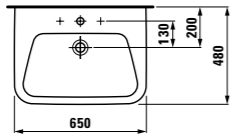

.104 .108 .109 .112



modernaplust
 81354.2
Countertop washbasin
 Waschtisch unterbaufähig
 Lavabo à poser sur meuble
 Lavabo consolle

81954.3
Pedestal, ceramic
 Säule, Keramik
 Colonne, céramique
 Colonna, ceramica

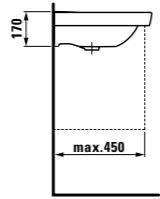
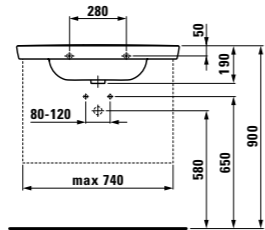
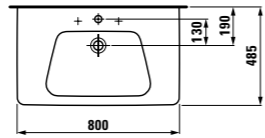

.104 .108 .109



modernaplust
 81354.2
Countertop washbasin
 Waschtisch unterbaufähig
 Lavabo à poser sur meuble
 Lavabo consolle

81954.3
Pedestal, ceramic
 Säule, Keramik
 Colonne, céramique
 Colonna, ceramica

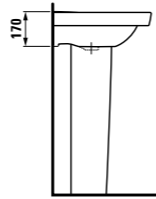
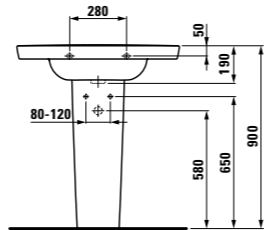
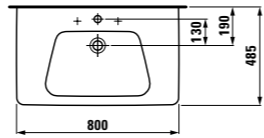

.104 .108 .109



modernaplust
 1354.2
Countertop washbasin
 Waschtisch unterbaufähig
 Lavabo à poser sur meuble
 Lavabo consolle

1954.4
Siphon cover, ceramic
 Siphonverkleidung, Keramik
 Cache-siphon, céramique
 Semicolonna, ceramica

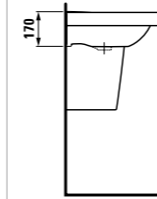
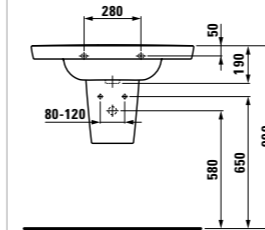
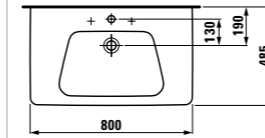

.104 .108 .109



modernaplust
 81354.4
Countertop washbasin
 Waschtisch unterbaufähig
 Lavabo à poser sur meuble
 Lavabo consolle

81954.3
Pedestal, ceramic
 Säule, Keramik
 Colonne, céramique
 Colonna, ceramica

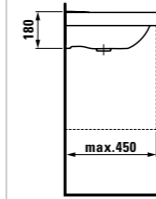
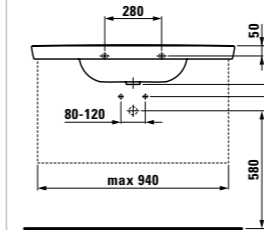
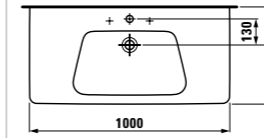

.104 .108 .109



modernaplust
 81354.4
Countertop washbasin
 Waschtisch unterbaufähig
 Lavabo à poser sur meuble
 Lavabo consolle

81954.3
Pedestal, ceramic
 Säule, Keramik
 Colonne, céramique
 Colonna, ceramica

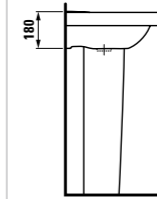
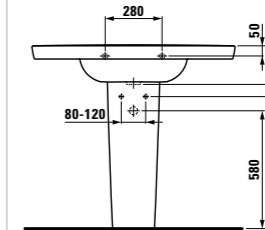
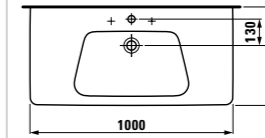

.104 .108 .109



modernaplust
 81354.4
Countertop washbasin
 Waschtisch unterbaufähig
 Lavabo à poser sur meuble
 Lavabo consolle

81954.4
Siphon cover, ceramic
 Siphonverkleidung, Keramik
 Cache-siphon, céramique
 Semicolonna, ceramica

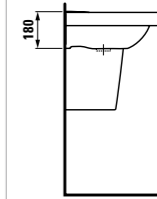
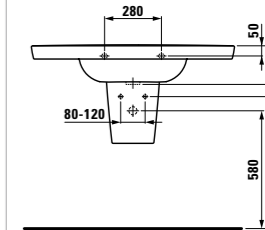
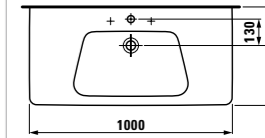

.104 .108 .109



modernaplust
 1354.2
Countertop washbasin
 Waschtisch unterbaufähig
 Lavabo à poser sur meuble
 Lavabo consolle

1954.4
Siphon cover, ceramic
 Siphonverkleidung, Keramik
 Cache-siphon, céramique
 Semicolonna, ceramica

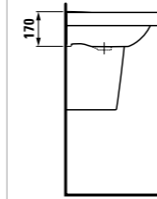
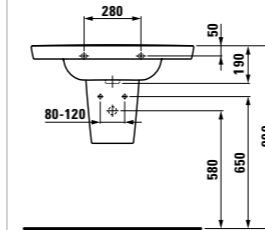
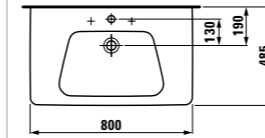

.104 .108 .109



modernaplust
 81354.4
Countertop washbasin
 Waschtisch unterbaufähig
 Lavabo à poser sur meuble
 Lavabo consolle

81954.3
Pedestal, ceramic
 Säule, Keramik
 Colonne, céramique
 Colonna, ceramica

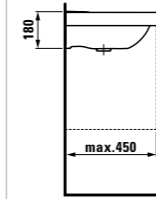
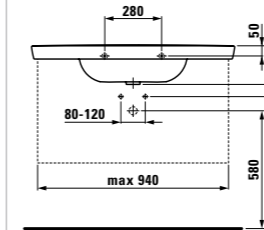
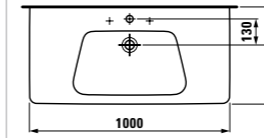

.104 .108 .109



modernaplust
 81354.4
Countertop washbasin
 Waschtisch unterbaufähig
 Lavabo à poser sur meuble
 Lavabo consolle

81954.3
Pedestal, ceramic
 Säule, Keramik
 Colonne, céramique
 Colonna, ceramica

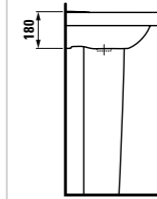
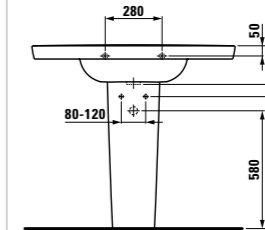
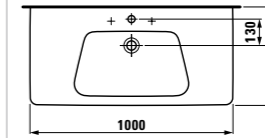

.104 .108 .109



modernaplust
 81354.4
Countertop washbasin
 Waschtisch unterbaufähig
 Lavabo à poser sur meuble
 Lavabo consolle

81954.4
Siphon cover, ceramic
 Siphonverkleidung, Keramik
 Cache-siphon, céramique
 Semicolonna, ceramica

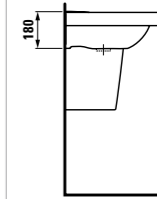
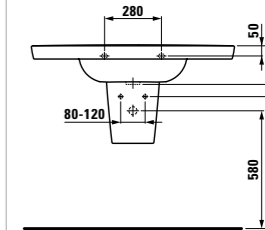
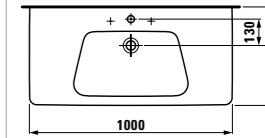

.104 .108 .109

modernaplust



ø1454.1 ○/●/●●●

Double countertop washbasin
 Doppelwaschtisch unterbaufähig
 Lavabo double à poser sur meuble
 Lavabo doppio consolle

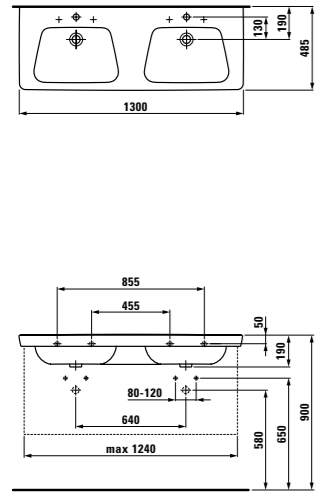
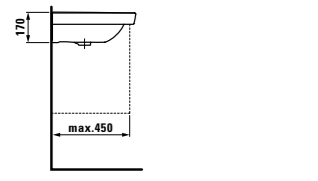
.104 .108 .109

modernaplust



ø1454.1 ○/●/●●●

Double countertop washbasin
 Doppelwaschtisch unterbaufähig
 Lavabo double à poser sur meuble
 Lavabo doppio consolle

ø1954.3
Pedestal, ceramic
 Säule, Keramik
 Colonne, céramique
 Colonna, ceramica

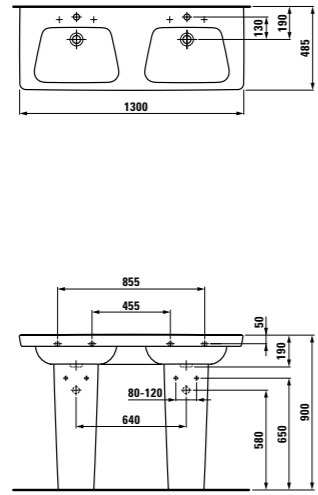
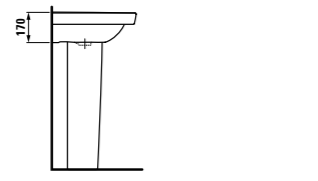
.104 .108 .109

modernaplust



ø1454.1 ○/●/●●●

Double countertop washbasin
 Doppelwaschtisch unterbaufähig
 Lavabo double à poser sur meuble
 Lavabo doppio consolle

ø1954.4
Siphon cover, ceramic
 Siphonverkleidung, Keramik
 Cache-siphon, céramique
 Semicolonna, ceramica

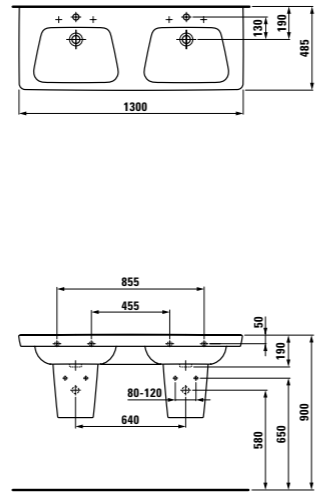
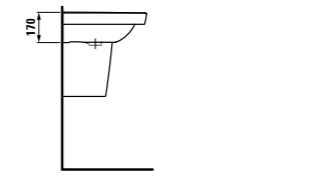
.104 .108 .109

modernaplust



ø1854.1 ○

Built-in washbasin
 Einbauwaschtisch von unten
 Lavabo à encastrer par le dessous
 Lavabo da incasso soprapiano

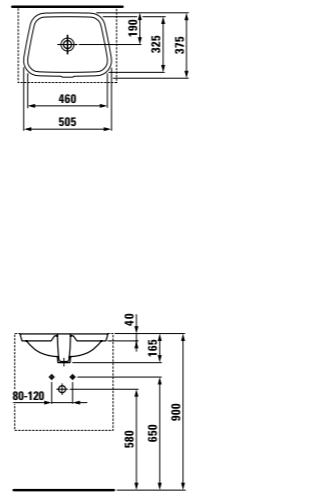
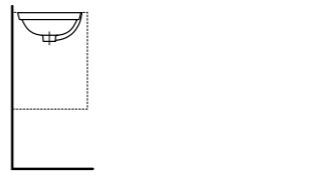
.109 .155

modernaplust



ø1654.1 ○/●

Small corner washbasin
 Eckhandwaschbecken
 Petit lave-main d'angle
 Lavabo angolare

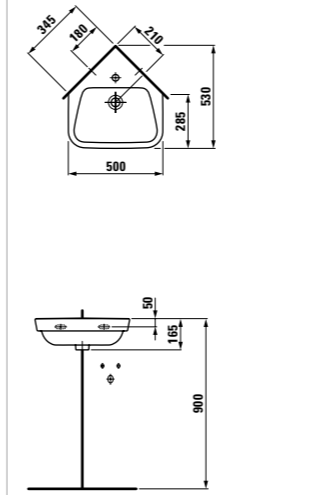
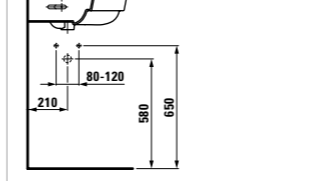
.104 .109

modernaplust



Ceramic shelf
 Keramikablage
 Etagère en céramique
 Mensola in ceramica

	A	B
ø7154.1	450	230
ø7154.4	600	360

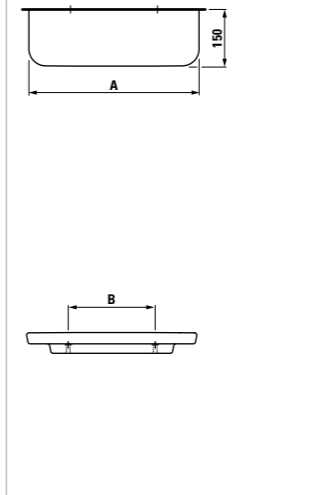

Types of washbasins
 Ausführungen Waschtische
 Exécutions lavabos
 Modelli lavabi

.000 / .104 **1 tap hole**
 1 Hahnloch
 1 trou pour la robinetterie
 1 foro per la rubinetteria

.108 **3 tap holes**
 3 Hahnlöcher
 3 trous pour la robinetterie
 3 fori per la rubinetteria

.109 **Without tap hole**
 Ohne Hahnloch
 Non percé
 Senza foro per la rubinetteria

.112 **Without tap hole, without overflow**
 Ohne Hahnloch, ohne Überlauf
 Non percé, sans trop-plein
 Senza foro per la rubinetteria, senza troppo-pieno









.155 **Without tap hole, glazed inside and outside**
 Ohne Hahnloch, innen und aussen glasiert
 Non percé, coupé sur 1 côté, émaillé sur l'intérieur et l'extérieur
 Senza foro per la rubinetteria, interno ed esterno smaltato

Types of bidet
 Ausführungen Bidet
 Exécutions bidet
 Modelli bidet

.000 / .302 **With 1 tap hole in centre, without mounting hole at sides for water inlet**
 Mit 1 Hahnloch mittig, ohne seitliches Loch für Wasseranschluss
 Avec 1 trou pour la robinetterie au milieu, sans trou sur le côté pour le raccordement de l'eau
 Con 1 foro centrale per la rubinetteria, senza foro laterale per l'attacco dell'acqua

.109 / .304 **With 1 tap hole in the middle, with mounting hole at sides for water inlet**
 Mit 1 Hahnloch mittig, mit seitlichem Loch für Wasseranschluss
 Avec 1 trou pour la robinetterie au milieu, avec trou sur le côté pour le raccordement de l'eau
 Con 1 foro centrale per la rubinetteria, con foro laterale per l'attacco

Ceramic colours
 Keramikfarben
 Couleurs céramique
 Colori della ceramica

-  .000 White / Weiss / Blanc / Bianco
-  .400 White / Weiss / Blanc / Bianco
-  LCC (Laufen Clean Coat)
-  .018 Bahamabeige / Beige Bahama
-  .037 Manhattan
-  .046 Whisperblue
-  .049 Pergamon
-  .050 Ägäis / Egée
-  .757 Edelweiss

modernaplust



82054.0
Wallhung WC, washdown
Wand-WC, Tiefspüler
WC suspendu, à chasse directe
Vaso sospeso, a cacciata

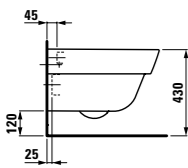
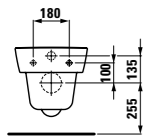
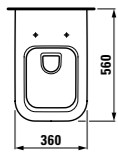

modernaplust



83054.1
Wallhung bidet
Wandbidet
Bidet suspendu
Bidet sospeso

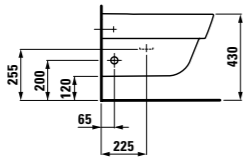
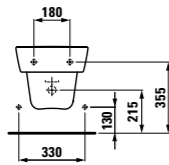
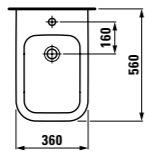

.302 .304

modernaplust



89154.0
Removable WC seat and cover, with anti-bacterial effect, stainless steel hinges
WC-Sitz mit Deckel, abnehmbar, mit antibakterieller Wirkung, Scharniere Edelstahl
Siège avec abattant, amovible, avec effet antibactérien, charnière en acier
Sedile copri water, estraibile, con effetto antibatterico, cerniere in acciaio inox

89154.1
Removable WC seat and cover, with hydraulic lowering system and anti-bacterial effect, stainless steel hinges
WC-Sitz mit Deckel, abnehmbar, mit hydraulischer Absenkautomatik und antibakterieller Wirkung, Scharniere Edelstahl
Siège avec abattant, amovible, avec abaissement automatique hydraulique et effet antibactérien, charnière en acier
Sedile copri water, estraibile, con sistema di abbassamento idraulico e con effetto antibatterico, cerniere in acciaio inox

moderna R



82054.1
Wallhung WC, washdown
Wand-WC, Tiefspüler
WC suspendu, à chasse directe
Vaso sospeso, a cacciata

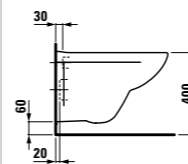
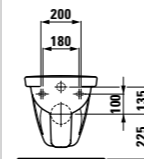
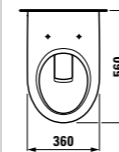

moderna R



83054.2
Wallhung bidet
Wandbidet
Bidet suspendu
Bidet sospeso

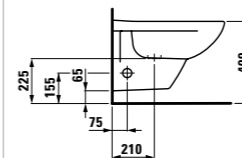
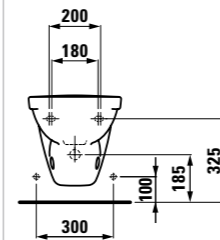
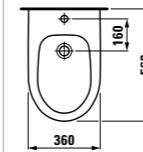

.304

moderna R



89346.0
Removable WC seat and cover, with anti-bacterial effect, stainless steel hinges
WC-Sitz mit Deckel, abnehmbar, mit antibakterieller Wirkung, Scharniere Edelstahl
Siège avec abattant, amovible, avec effet antibactérien, charnière en acier
Sedile copri water, estraibile, con effetto antibatterico, cerniere in acciaio inox

89346.1
Removable WC seat and cover, with hydraulic lowering system and anti-bacterial effect, stainless steel hinges
WC-Sitz mit Deckel, abnehmbar, mit hydraulischer Absenkautomatik und antibakterieller Wirkung, Scharniere Edelstahl
Siège avec abattant, amovible, avec abaissement automatique hydraulique et effet antibactérien, charnière en acier
Sedile copri water, estraibile, con sistema di abbassamento idraulico e con effetto antibatterico, cerniere in acciaio inox

89346.2
Removable WC seat and cover, with hydraulic lowering system and anti-bacterial effect, plastic hinges
WC-Sitz mit Deckel, abnehmbar, mit hydraulischer Absenkautomatik und antibakterieller Wirkung, Scharniere Kunststoff
Siège avec abattant, amovible, avec abaissement automatique hydraulique et effet antibactérien, charnière en plastique
Sedile copri water, estraibile, con sistema di abbassamento idraulico e con effetto antibatterico, cerniere in plastica

moderna R



82054.5
Wallhung WC, for Cistern
Wand-WC, für Spülkasten
WC suspendu, pour réservoir de chasse d'eau
Vaso sospeso, per cassetta di sciacquo



82646.0
Cistern
Spülkasten
Réservoir de chasse d'eau
Cassetta di sciacquo



82054.3
Wallhung WC, Compact
Wand-WC, kompakt
WC suspendu, compact
Vaso sospeso, compatto



Erhältlich ab Ende September 2010

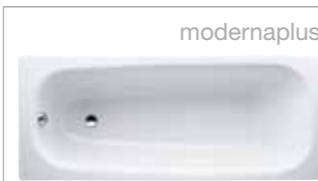
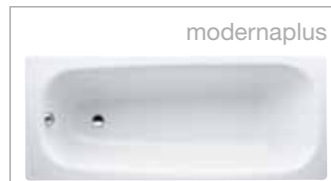

22514.0
Steel bathtub, 1600x700 mm, 3,5 mm enamelled steel, with antinoise pads
Stahlbadewanne, 1600x700 mm, Stahl-Email 3,5 mm, mit Anti-Noise-Pads
Baignoire acier, 1600x700 mm, acier émaillé de 3,5 mm, avec coussinets anti-bruit
Vasca in acciaio, 1600x700 mm, acciaio smaltato 3,5 mm, con cuscinetti anti-rumore

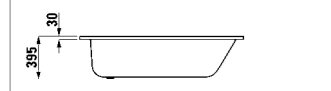
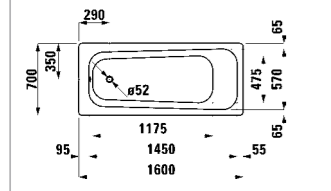

22512.0
Steel bathtub, 1700x700 mm, 3,5 mm enamelled steel, with antinoise pads
Stahlbadewanne, 1700x700 mm, Stahl-Email 3,5 mm, mit Anti-Noise-Pads
Baignoire acier, 1700x700 mm, acier émaillé de 3,5 mm, avec coussinets anti-bruit
Vasca in acciaio, 1700x700 mm, acciaio smaltato 3,5 mm, con cuscinetti anti-rumore

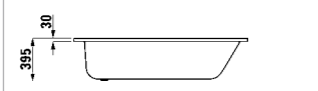
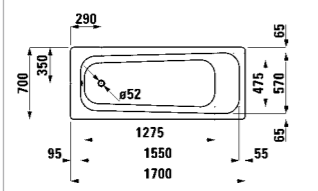

22513.0
Steel bathtub, 1700x750 mm, 3,5 mm enamelled steel, with antinoise pads
Stahlbadewanne, 1700x750 mm, Stahl-Email 3,5 mm, mit Anti-Noise-Pads
Baignoire acier, 1700x750 mm, acier émaillé de 3,5 mm, avec coussinets anti-bruit
Vasca in acciaio, 1700x750 mm, acciaio smaltato 3,5 mm, con cuscinetti anti-rumore

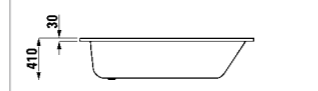
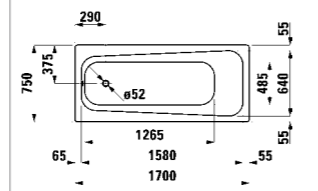

29410.3.016.000.1
Gel pillow, self-adhesive
Gelkissen selbsthaftend
Coussin-gel adhérent
Cuscino in gel autoadesivo

Bathtub colours
Farben Badewannen
Couleurs baignoires
Colori delle vasche

- .000 White / Weiss / Blanc / Bianco
- .600 White with Antislip
Weiss mit Antislip
Blanc avec fond antidérapant
Bianco con fondo antiscivolo

Taphole options / Hahnloch-Optionen / Option trou pour la robinetterie / Opzioni foro per la rubinetteria

045
For one-hole bath single-lever mixer article number 9.40080.100.085, one taphole on the left corner next to the outlet
Für Einloch-Badmischer Artikelnummer 9.40080.100.085, ein Hahnloch in der linken Ecke beim Ablauf
Pour mitigeur de bain monotrou, article numéro 9.40080.100.085, un trou pour la robinetterie à l'angle gauche près de l'écoulement
Miscelatore da bagno monoforo articolo numero 9.40080.100.085, foro singolo per la rubinetteria nell'angolo sinistro vicino allo scarico

046
For one-hole bath single-lever mixer article number 9.40080.100.085, one taphole on the right corner next to the outlet
Für Einloch-Badmischer Artikelnummer 9.40080.100.085, ein Hahnloch in der rechten Ecke beim Ablauf
Pour mitigeur de bain monotrou, article numéro 9.40080.100.085, un trou pour la robinetterie à l'angle droit près de l'écoulement
Miscelatore da bagno monoforo articolo numero 9.40080.100.085, foro singolo per la rubinetteria nell'angolo destro vicino allo scarico

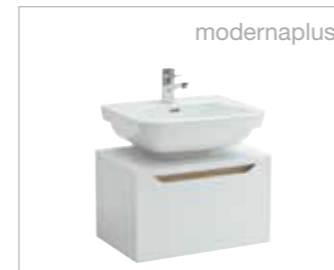

Vanity unit, 1 drawer, matches washbasins 8.1054.1, 8.1054.2, 8.1054.3, washbasin left
Waschtischunterbau, 1 Schublade, passend zu Waschtischen 8.1054.1, 8.1054.2, 8.1054.3
Meuble sous lavabo, 1 tiroir, pour lavabos 8.1054.1, 8.1054.2, 8.1054.3
Base sottolavabo, 1 cassetto, abbinabile ai lavabi 8.1054.1, 8.1054.2, 8.1054.3

42511.1
Without interior drawer
Ohne Innenschublade
Sans tiroir intérieur
Senza cassetto interno

42511.2
With interior drawer
Mit Innenschublade
Avec tiroir intérieur
Con cassetto interno

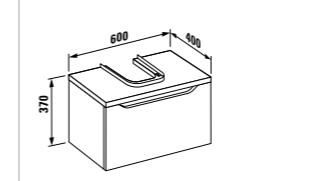

Vanity unit, 1 drawer, matches washbasins 8.1054.1, 8.1054.2, 8.1054.3, washbasin left
Waschtischunterbau, 1 Schublade, passend zu Waschtischen 8.1054.1, 8.1054.2, 8.1054.3
Meuble sous lavabo, 1 tiroir, pour lavabos 8.1054.1, 8.1054.2, 8.1054.3, lavabo à gauche
Base sottolavabo, 1 cassetto, abbinabile ai lavabi 8.1054.1, 8.1054.2, 8.1054.3, lavabo a sinistra

42513.1
Without interior drawer
Ohne Innenschublade
Sans tiroir intérieur
Senza cassetto interno

42513.2
With interior drawer
Mit Innenschublade
Avec tiroir intérieur
Con cassetto interno

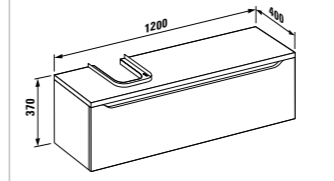

Vanity unit, 1 drawer, matches washbasins 8.1054.1, 8.1054.2, 8.1054.3, washbasin right
Waschtischunterbau, 1 Schublade, passend zu Waschtischen 8.1054.1, 8.1054.2, 8.1054.3
Meuble sous lavabo, 1 tiroir, pour lavabos 8.1054.1, 8.1054.2, 8.1054.3, lavabo à droite
Base sottolavabo, 1 cassetto, abbinabile ai lavabi 8.1054.1, 8.1054.2, 8.1054.3, lavabo a destra

42514.1
Without interior drawer
Ohne Innenschublade
Sans tiroir intérieur
Senza cassetto interno

42514.2
With interior drawer
Mit Innenschublade
Avec tiroir intérieur
Con cassetto interno

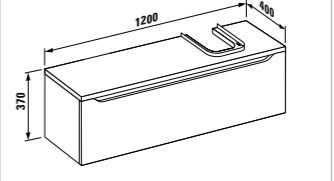

Vanity unit, 1 drawer, matches washbasins 8.1054.1, left and right
Waschtischunterbau, 1 Schublade, passend zu Waschtisch 8.1054.1, links und rechts
Meuble sous lavabo, 1 tiroir, pour lavabo 8.1054.1, à droite et à gauche
Base sottolavabo, 1 cassetto, abbinabile ai lavabo 8.1054.1, a sinistra e a destra

42512.1
Without interior drawer
Ohne Innenschublade
Sans tiroir intérieur
Senza cassetto interno

42512.2
With interior drawer
Mit Innenschublade
Avec tiroir intérieur
Con cassetto interno

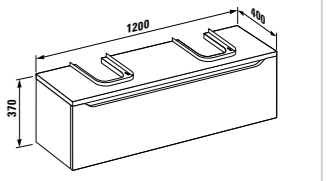

modernaplust



43511.1
Vanity unit, 1 drawer, matches washbasin 8.1354.2
 Waschtischunterbau, 1 Schublade, passend zu Waschtisch 8.1354.2
 Meuble sous lavabo, 1 tiroir, pour lavabo 8.1354.2
 Base sottolavabo, 1 cassetto, abbinabile ai lavabo 8.1354.2

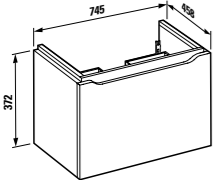

modernaplust



43512.1
Vanity unit, 1 drawer, matches washbasin 8.1354.4
 Waschtischunterbau, 1 Schublade, passend zu Waschtisch 8.1354.4
 Meuble sous lavabo, 1 tiroir, pour lavabo 8.1354.4
 Base sottolavabo, 1 cassetto, abbinabile ai lavabo 8.1354.4

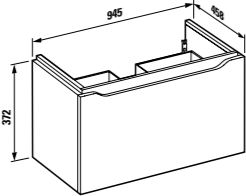

modernaplust



43513.1
Vanity unit, 1 drawer, matches washbasin 8.1454.1
 Waschtischunterbau, 1 Schublade, passend zu Waschtisch 8.1454.1
 Meuble sous lavabo, 1 tiroir, pour lavabo 8.1454.1
 Base sottolavabo, 1 cassetto, abbinabile ai lavabo 8.1454.1

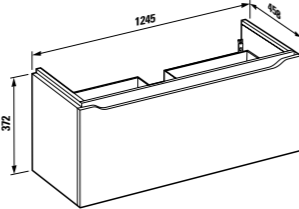

modernaplust



42510.1
Vanity unit corner, 1 door, matches washbasin 8.1654.1
 Eckwaschtischunterbau, 1 Tür, passend zu Waschtisch 8.1654.1
 Meuble sous lavabo d'angle, 1 porte, pour lavabo 8.1654.1
 Base sottolavabo angolare, 1 anta, abbinabile ai lavabo 8.1654.1



modernaplust



Tall cabinet, 1 drawer, 1 door with 3 glass shelves and 1 removable box
 Hochschrank, 1 Schublade, 1 Tür mit 3 Glasablagen und 1 herausnehmbaren Behälter
 Armoire, 1 tiroir, 1 porte avec 3 étagères en verre et une boîte amovible
 Colonna, 1 cassetto, 1 anta con 3 ripiani di vetro e 1 contenitore estraibile

46610.1
Door hinge left
 Türanschlag links
 Charnières de porte à gauche
 Anta con apertura verso sinistra

46610.2
Door hinge right
 Türanschlag rechts
 Charnières de porte à droite
 Anta con apertura verso destra



modernaplust



46611.2
Trolley, 1 drawer, 1 door with hinges right, 1 glass shelf, 1 cosmetic box with mirror on top
 Rollcontainer, 1 Schublade, 1 Tür mit Anschlag rechts, 1 Glasablage, 1 Kosmetikbehälter mit Spiegel auf der Oberseite
 Container à roulettes, 1 tiroir, 1 porte avec charnières à droite, 1 étagère en verre, 1 boîte à cosmétiques avec miroir sur le dessus
 Base su ruote, 1 cassetto, 1 anta con apertura verso destra, 1 ripiano di vetro, 1 porta-cosmetici con specchio

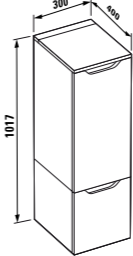

modernaplust



Mirror 800 with lighting
 Spiegel 800 mit Beleuchtungselement
 Miroir 800 avec élément d'éclairage
 Specchio 800 con elemento d'illuminazione

44513.1
1 switch
 1 Schalter
 1 interrupteur
 1 interruttore

44513.3
No switch
 Kein Schalter
 Pas d'interrupteur
 Senza interruttore



modernaplust



Mirror 1000 with lighting
 Spiegel 1000 mit Beleuchtungselement
 Miroir 1000 avec élément d'éclairage
 Specchio 1000 con elemento d'illuminazione

44514.1
1 switch
 1 Schalter
 1 interrupteur
 1 interruttore

44514.3
No switch
 Kein Schalter
 Pas d'interrupteur
 Senza interruttore





Mirror 1200 with lighting
 Spiegel 1200 mit Beleuchtungselement
 Miroir 1200 avec élément d'éclairage
 Specchio 1200 con elemento d'illuminazione

44515.1
1 switch
 1 Schalter
 1 interrupteur
 1 interruttore

44515.3
No switch
 Kein Schalter
 Pas d'interrupteur
 Senza interruttore

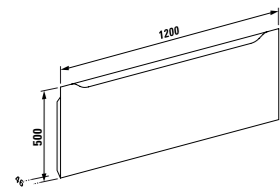

Mirror cabinet corner with lighting, 2 glass shelves
 Eckspiegelschrank, mit Beleuchtung, 2 Glasfachböden
 Armoire de toilette d'angle avec miroir, avec éclairage, 2 étagères en verre
 Armadietto a specchio angolare, con illuminazione, 2 ripiani di vetro

44510.1
1 switch, 1 socket Europe
 1 Schalter, 1 Steckdose Europa
 1 interrupteur, 1 prise Europe
 1 interruttore, 1 presa Europa

44510.3
No switch, 1 socket Switzerland
 Kein Schalter, 1 Steckdose Schweiz
 Pas d'interrupteur, 1 prise Suisse
 Senza interruttore, 1 presa Svizzera

44510.5
No switch, no socket
 Kein Schalter, keine Steckdose
 Pas d'interrupteur, pas de prise
 Senza interruttore, senza presa

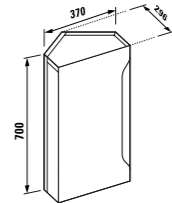

Mirror cabinet 500 with lighting, 2 glass shelves, door hinge left
 Spiegelschrank 500 mit Beleuchtung, 2 Glasfachböden, Türanschlag links
 Armoire de toilette avec éclairage, 2 étagères en verre, Charnières de porte à gauche
 Armadietto a specchio con illuminazione, 2 ripiani di vetro, Anta con apertura verso sinistra

44511.1
1 switch, 1 socket Europe
 1 Schalter, 1 Steckdose Europa
 1 interrupteur, 1 prise Europe
 1 interruttore, 1 presa Europa

44511.3
No switch, 1 socket Switzerland
 Kein Schalter, 1 Steckdose Schweiz
 Pas d'interrupteur, 1 prise Suisse
 Senza interruttore, 1 presa Svizzera

44511.5
No switch, no socket
 Kein Schalter, keine Steckdose
 Pas d'interrupteur, pas de prise
 Senza interruttore, senza presa

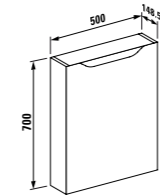

Mirror cabinet 500 with lighting, 2 glass shelves, door hinge right
 Spiegelschrank 500 mit Beleuchtung, 2 Glasfachböden, Türanschlag rechts
 Armoire de toilette 500 avec éclairage, 2 étagères en verre, charnières de porte à droite
 Armadietto a specchio 500 con illuminazione, 2 ripiani di vetro, anta con apertura verso destra

44516.1
1 switch, 1 socket Europe
 1 Schalter, 1 Steckdose Europa
 1 interrupteur, 1 prise Europe
 1 interruttore, 1 presa Europa

44516.3
No switch, 1 socket Switzerland
 Kein Schalter, 1 Steckdose Schweiz
 Pas d'interrupteur, 1 prise Suisse
 Senza interruttore, 1 presa Svizzera

44516.5
No switch, no socket
 Kein Schalter, keine Steckdose
 Pas d'interrupteur, pas de prise
 Senza interruttore, senza presa

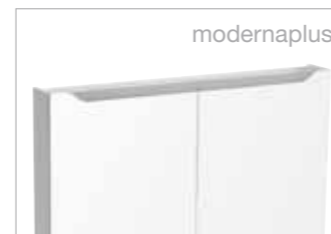
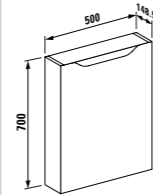

Mirror cabinet 1200 with lighting, 4 glass shelves
 Spiegelschrank 1200 mit Beleuchtung, 4 Glasfachböden
 Armoire de toilette 1200 avec éclairage, 4 étagères en verre
 Armadietto a specchio 1200 con illuminazione, 4 ripiani di vetro

44512.1
1 switch, 1 socket Europe
 1 Schalter, 1 Steckdose Europa
 1 interrupteur, 1 prise Europe
 1 interruttore, 1 presa Europa

44512.3
No switch, 1 socket Switzerland
 Kein Schalter, 1 Steckdose Schweiz
 Pas d'interrupteur, 1 prise Suisse
 Senza interruttore, 1 presa Svizzera

44512.5
No switch, no socket
 Kein Schalter, keine Steckdose
 Pas d'interrupteur, pas de prise
 Senza interruttore, senza presa

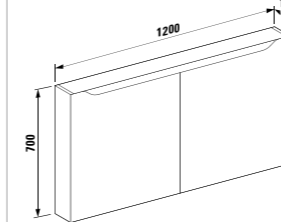

Colour of furniture

Möbelfarbe
 Couleur des meubles
 Colore dei mobili

.000 White / Weiss / Blanc / Bianco

Panels can be exchanged freely with the colours.

Die Farben für die Blenden sind frei wählbar.
 Les couleurs des panneaux sont au choix.
 I pannelli possono essere cambiati a scelta con i colori.

- .390 Blue / Blau / Bleu / Blu
- .391 Red / Rot / Rouge / Rosso
- .392 Black / Schwarz / Noir / Nero
- .393 Grey / Grau / Gris / Grigio
- .394 Wenge / Wenge / Wengé / Wenge
- .395 Natural oak / Eiche Natur / Chêne naturel / Rovere naturale



Basin single-lever mixer, fixed spout 110mm
 Waschtischmischer, Festauslauf 110mm
 Mitigeur de lavabo, bec fixe 110mm
 Miscelatore per lavabo, bocca di erogazione fissa 110mm

440002.100.000
Without pop-up waste
 Ohne Ablaufventil
 Sans vidage
 Senza piletta

440012.100.000
Ecototal+, without pop-up waste
 Ecototal+, ohne Ablaufventil
 Ecototal+, sans vidage
 Ecototal+, senza piletta

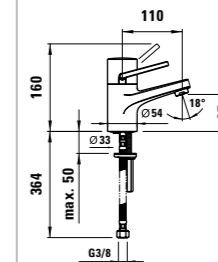

440001.100.000
With pop-up waste
 Mit Ablaufventil
 Avec vidage
 Con piletta

440011.100.000
Ecototal+, with pop-up waste
 Ecototal+, mit Ablaufventil
 Ecototal+, avec vidage
 Ecototal+, con piletta

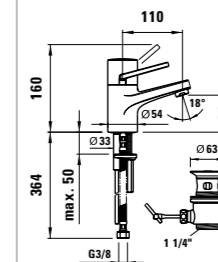

Basin single-lever mixer, swivel spout 145mm
 Waschtischmischer, Schwenkauslauf 145mm
 Mitigeur de lavabo, bec orientable, saillie 145mm
 Miscelatore per lavabo, bocca di erogazione orientabile, sporgenza 145mm

440008.100.000
without pop-up waste
 Ohne Ablaufventil
 Sans vidage
 Senza piletta

440018.100.000
Ecototal+, without pop-up waste
 Ecototal+, ohne Ablaufventil
 Ecototal+, sans vidage
 Ecototal+, senza piletta

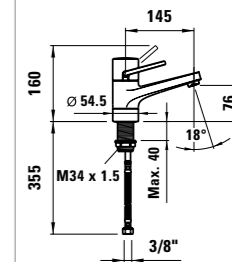

440007.100.000
With pop-up waste
 Mit Ablaufventil
 Avec vidage
 Con piletta

440017.100.000
Ecototal+, with pop-up waste
 Ecototal+, mit Ablaufventil
 Ecototal+, avec vidage
 Ecototal+, con piletta

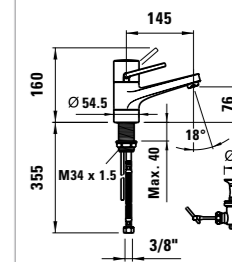



940019.100.000
Standing column basin mixer, swivel spout 145mm, without pop-up waste
 Standsäule Waschtischmischer, Schwenkauslauf 145mm, ohne Ablaufventil
 Mitigreur de lavabo à bec rehaussé, bec orientable, saillie 145mm, sans vidage
 Miscelatore per lavabo a colonna integrata, bocca di erogazione orientabile 145 mm, senza piletta

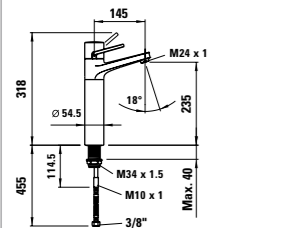

940010.100.000
Bidet single-lever mixer, fixed spout 110mm, with pop-up waste
 Bidetmischer, Festauslauf 110mm, mit Ablaufventil
 Mitigreur de bidet, bec fixe 110mm, avec vidage
 Miscelatore per bidet, bocca di erogazione fissa 110 mm, con piletta

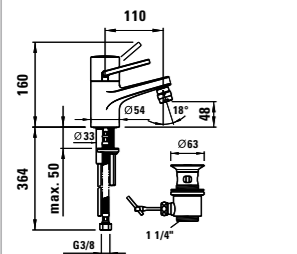

940060.100.000
Bath single-lever mixer complete, with flexible hose 1800 mm and Aquajet Multi handspray
 Bademischer komplett, mit Kunststoffschlauch 1800 mm und Handbrause Aquajet Multi
 Mitigreur de bain complet, avec flexible synthétique 1800 mm et douche à main Aquajet Multi
 Miscelatore completo da bagno, tubo sintetico 1800mm e doccetta a mano Aquajet Multi

940060.100.010
Bath single-lever mixer, without nuts, without accessories
 Bademischer, ohne Verschraubungen, ohne Zubehör
 Mitigreur de bain, sans raccords, sans accessoires
 Miscelatore da bagno, senza raccordi, senza accessori

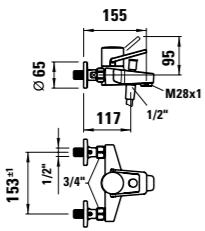

940050.100.000
Shower single-lever mixer complete, with flexible hose 1800 mm and Aquajet Multi handspray
 Duschenmischer komplett, mit Kunststoffschlauch 1800 mm und Handbrause Aquajet Multi
 Mitigreur de douche complet, avec flexible synthétique 1800 mm et douche à main Aquajet Multi
 Miscelatore da doccia completo, tubo sintetico 1800 mm e doccetta a mano Aquajet Multi

940050.100.010
Shower single-lever mixer, without nuts, without accessories
 Duschenmischer, ohne Verschraubungen, ohne Zubehör
 Mitigreur de douche, sans raccords, sans accessoires
 Miscelatore da doccia, senza raccordi, senza accessori

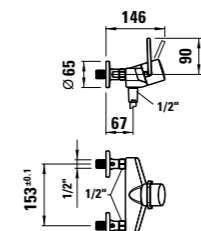

940079.100.000
Set for concealed bath mixer Simibox with diverter
 Fertigmontage-Set für Unterputz-Bademischer Simibox
 Habillage extérieur pour mitigreur de bain encastré Simibox
 Miscelatore da bagno ad incasso Simibox

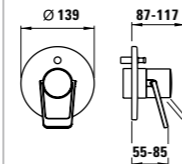

940078.100.000
Set for concealed shower mixer Simibox
 Fertigmontage-Set für Unterputz-Duschenmischer Simibox
 Habillage extérieur pour mitigreur de douche encastré Simibox
 Miscelatore da doccia ad incasso Simibox

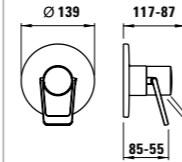

940083.100.050
Roman tub filler 3-holes, without plate
 Wannenfüllkombination 3-Loch, ohne Platte
 Garniture de remplissage de baignoire 3 trous, sans plaque
 Rubinetteria per vasca, 3 fori, senza piastra

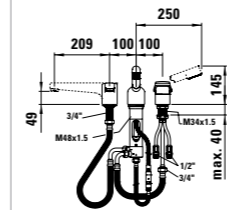

940083.100.000
Roman tub filler 3-holes, on straight plate
 Wannenfüllkombination 3-Loch, auf Platte
 Garniture de remplissage de baignoire 3 trous, sur plaque
 Rubinetteria per vasca, 3 fori, su piastra

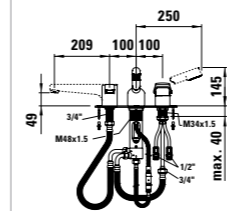

940080.100.085
One-hole bath single-lever mixer complete, with flexible hose 1800 mm and Aquajet Multi handspray, for mounting Set 1.03476.000.000
 Einloch-Bademischer komplett, mit Kunststoffschlauch 1800 mm und Handbrause Aquajet Multi, für Sockel 1.03476.000.000
 Mitigreur de bain mono trou complet, avec flexible synthétique 1800 mm et douche à main Aquajet Multi, pour socle 1.03476.000.000
 Miscelatore da bagno completo monoforo, tubo sintetico 1800mm e doccetta a mano Aquajet Multi, per set 1.03476.000.000

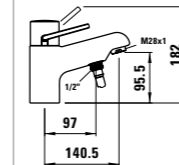

103476.000.000
Mounting set for one-hole bath single lever mixer 9.40080.100.085
 Einbausockel für Einloch-Bademischer 9.40080.100.085
 Socle de montage pour mitigreur de bain mono trou 9.40080.100.085
 Base di montaggio per miscelatore da bagno monoforo 9.40080.100.085

103476.000.060
With extension of 40cm
 Mit verlängerten CU-Rohren von 40cm
 Avec rallonge de 40cm
 Con prolunga di 40 cm



574007.000.000
Simibox
Concealed box for bath and shower mixer
 Unterputz-Einbaukörper für Bade- und Duschenmischer
 Corps encastré pour mitigreur de bain et de douche
 Corpo ad incasso per miscelatore da bagno e da doccia

529030.941.000
Mounting aid for Simibox
 Montagehilfe für Simibox
 Aide de montage pour Simibox
 Set di montaggio per Simibox

577032.000.000
Flange for Simibox
 Flansch für Simibox
 Bride pour Simibox
 Flangia per Simibox

530012.000.000
Extension set L = 25 mm
 Verlängerungsset L = 25 mm
 Rallonge L = 25 mm
 Prolunga a L = 25 mm

530013.000.000
Extension set L = 50 mm
 Verlängerungsset L = 50 mm
 Rallonge L = 50 mm
 Prolunga a L = 50 mm



All arwa-class M faucets are equipped with the Ecototal cartridge, that saves valuable water and energy thanks to the integrated water flow and temperature restraints. Ecototal+, with the cold water lever positioned in the middle, allows additional energy savings. Quality faucets by arwa.

Alle arwa-class M Armaturen verfügen über die Ecototal Sparkartusche, die dank integrierter Mengen- und Temperaturbremsen wertvolles Wasser und Energie spart. Dank Ecototal+, mit der Kaltwasserstellung in der Mitte, ist ein zusätzliches Energie Sparpotential vorhanden. Qualitätsarmaturen von arwa.

Toute la gamme de robinetterie arwa-class M est dotée de la cartouche Ecototal, qui grâce aux freins de débit et de température intégrés, permet une précieuse économie d'eau et d'énergie. Ecototal+, avec le levier d'eau froide dans l'axe central, permet un potentiel d'économie d'énergie supplémentaire. Robinetterie de qualité de arwa.

Tutti i rubinetti arwa-class M sono provvisti della cartuccia di risparmio Ecototal che, grazie a speciali limitatori della quantità e della temperatura, permettono di risparmiare acqua ed energia preziosa. Inoltre, Ecototal+, con la posizione dell'acqua fredda nel centro, offre un ulteriore potenziale di risparmio energetico. Rubinetterie di qualità di arwa.

moderna



ø1546.0
Small washbasin
Handwaschbecken
Lave-mains
Lavamani



ø1946.5
Siphon cover, ceramic
Siphonverkleidung, Keramik
Cache-siphon, céramique
Semicolonna, ceramica

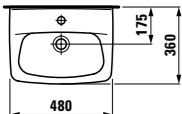
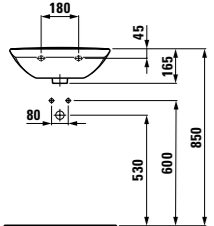
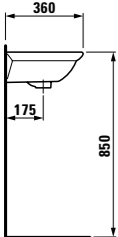



.000 .109 .112

moderna



ø1546.0
Small washbasin
Handwaschbecken
Lave-mains
Lavamani



ø1946.5
Siphon cover, ceramic
Siphonverkleidung, Keramik
Cache-siphon, céramique
Semicolonna, ceramica

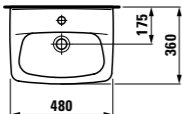
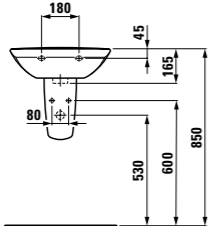
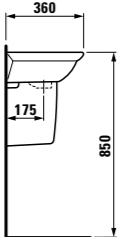



.000 .109 .112

moderna



ø1046.1
Washbasin
Waschtisch
Lavabo
Lavabo



ø1946.5
Siphon cover, ceramic
Siphonverkleidung, Keramik
Cache-siphon, céramique
Semicolonna, ceramica

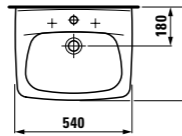
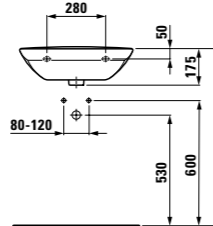
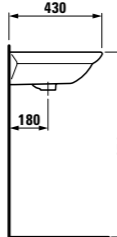



.000 .108 .109 .112

moderna



ø1046.1
Washbasin
Waschtisch
Lavabo
Lavabo



ø1946.0
Pedestal, ceramic
Säule, Keramik
Colonne, céramique
Colonna, ceramica

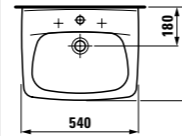
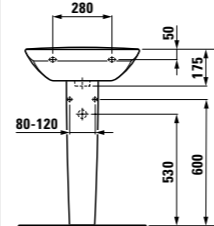
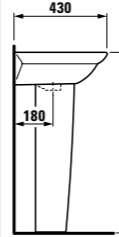



.000 .108 .109 .112

moderna



ø1046.1
Washbasin
Waschtisch
Lavabo
Lavabo



ø1946.1
Siphon cover, ceramic
Siphonverkleidung, Keramik
Cache-siphon, céramique
Semicolonna, ceramica

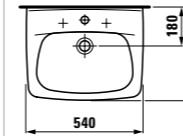
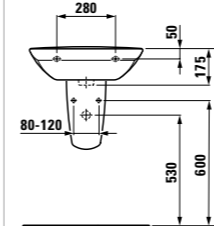
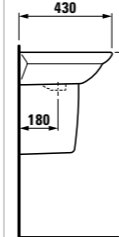



.000 .108 .109 .112

moderna



ø1046.2
Washbasin
Waschtisch
Lavabo
Lavabo



ø1946.0
Pedestal, ceramic
Säule, Keramik
Colonne, céramique
Colonna, ceramica

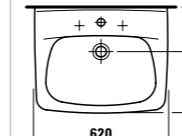
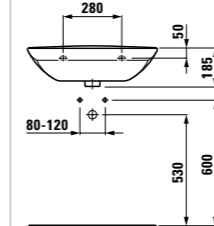
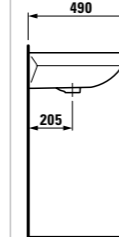



.000 .108 .109 .112

moderna



ø1046.2
Washbasin
Waschtisch
Lavabo
Lavabo



ø1946.0
Pedestal, ceramic
Säule, Keramik
Colonne, céramique
Colonna, ceramica

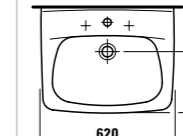
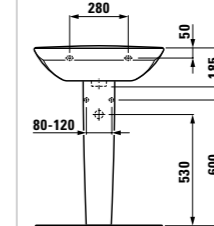
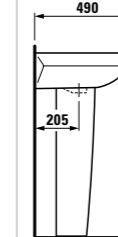



.000 .108 .109 .112

moderna



ø1046.2
Washbasin
Waschtisch
Lavabo
Lavabo



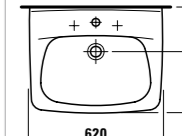
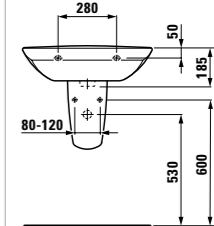
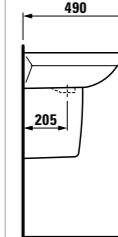

ø1946.1
Siphon cover, ceramic
Siphonverkleidung, Keramik
Cache-siphon, céramique
Semicolonna, ceramica

.000 .108 .109 .112

moderna



81246.2 

Countertop washbasin
Waschtisch unterbaufähig
Lavabo à poser sur meuble
Lavabo consolle

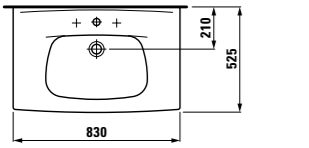
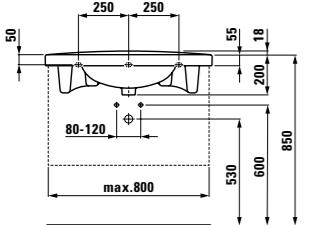
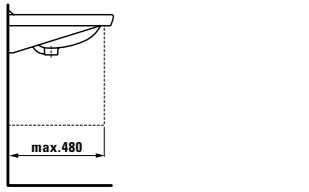
.000 .108 .109

moderna



81246.4 

Countertop washbasin
Waschtisch unterbaufähig
Lavabo à poser sur meuble
Lavabo consolle

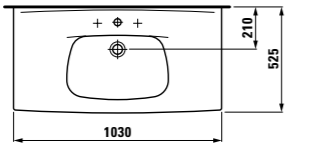
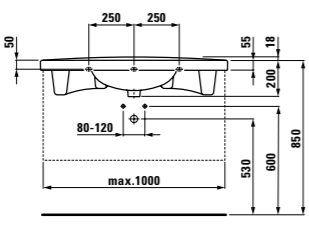
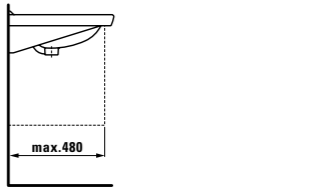
.000 .108 .109

moderna



81446.8 

Double countertop washbasin
Doppelwaschtisch unterbaufähig
Lavabo double à poser sur meuble
Lavabo doppio consolle

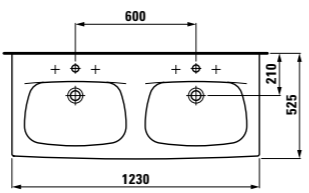
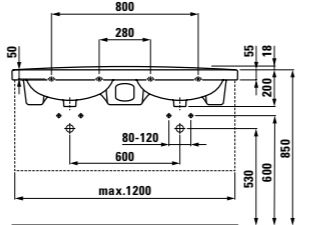
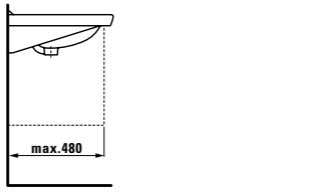

.000 .108 .109

moderna

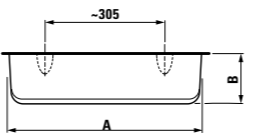

Ceramic shelf
Keramikablage
Etagère en céramique
Mensola in ceramica

	A	B	C	D
87003.2	480	145	55	35
87003.3	540	145	55	35
87003.4	620	155	60	40

Types of washbasins
Ausführungen Waschtische
Exécutions lavabos
Modelli lavabi

.000 / .104 **1 tap hole**
1 Hahnloch
1 trou pour la robinetterie
1 foro per la rubinetteria

.108 **3 tap holes**
3 Hahnlöcher
3 trous pour la robinetterie
3 fori per la rubinetteria

.109 **Without tap hole**
Ohne Hahnloch
Non percé
Senza foro per la rubinetteria

.112 **Without tap hole, without overflow**
Ohne Hahnloch, ohne Überlauf
Non percé, sans trop-plein
Senza foro per la rubinetteria, senza troppo-pieno

.155 **Without tap hole, glazed inside and out side**
Ohne Hahnloch, innen und aussen glasiert
Non percé, coupé sur 1 côté, émaillé sur l'intérieur et l'extérieur
Senza foro per la rubinetteria, interno ed esterno smaltato

Types of bidet
Ausführungen Bidet
Exécutions bidet
Modelli bidet

.000 / .302 **With 1 tap hole in centre, without mounting hole at sides for water inlet**
Mit 1 Hahnloch mittig, ohne seitliches Loch für Wasseranschluss
Avec 1 trou pour la robinetterie au milieu, sans trou sur le côté pour le raccordement de l'eau
Con 1 foro centrale per la rubinetteria, senza foro laterale per l'attacco dell'acqua

.109 / .304 **With 1 tap hole in the middle, with mounting hole at sides for water inlet**
Mit 1 Hahnloch mittig, mit seitlichem Loch für Wasseranschluss
Avec 1 trou pour la robinetterie au milieu, avec trou sur le côté pour le raccordement de l'eau
Con 1 foro centrale per la rubinetteria, con foro laterale per l'attacco dell'acqua

moderna



82346.1 **Floor-standing WC, for cistern (without cistern), washdown with horizontal outlet 150 mm**
Stand-WC, für Spülkasten (ohne Spülkasten), Tiefspüler mit waagrechttem Abgang 150 mm
WC au sol, pour réservoir de chasse d'eau (sans réservoir), à chasse directe avec sortie horizontale 150 mm
Vaso monoblocco a pavimento, per cassetta di sciacquo (senza cassetta di sciacquo), a cacciata con scarico a parete 150 mm





moderna



82346.2 **Floor-standing WC, for cistern (without cistern), washdown with horizontal outlet 250 mm**
Stand-WC, für Spülkasten (ohne Spülkasten), Tiefspüler mit waagrechttem Abgang 250 mm
WC au sol, pour réservoir de chasse d'eau (sans réservoir), à chasse directe avec sortie horizontale 250 mm
Vaso monoblocco a pavimento, per cassetta di sciacquo (senza cassetta di sciacquo), a cacciata con scarico a parete 250 mm





moderna



82446.0 **Wallhung WC, for cistern (without cistern), washdown**
Wand-WC, für Spülkasten (ohne Spülkasten), Tiefspüler WC suspendu, pour réservoir de chasse d'eau (sans réservoir), à chasse directe
Vaso sospeso, per cassetta di sciacquo (senza cassetta di sciacquo), a cacciata







moderna

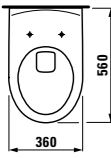
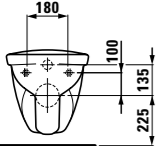
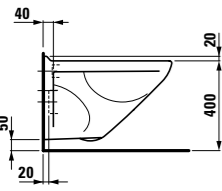

§2546.5
Wallhung WC, washdown
Wand-WC, Tiefspüler
WC suspendu, à chasse directe
Vaso sospeso, a cacciata

moderna



§2546.7
Wallhung WC Compact, washdown
Wand-WC Compact, Tiefspüler
WC suspendu Compact, à chasse directe
Vaso sospeso Compact, a cacciata

moderna

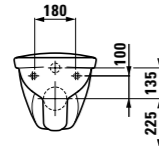
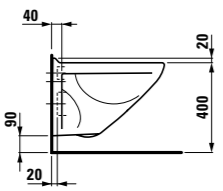

§3046.0
Floor-standing bidet
Standbidet
Bidet au sol
Bidet a pavimento



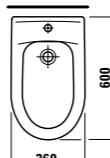
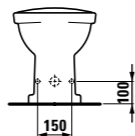
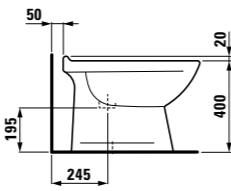

.000 .109

moderna

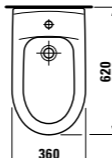
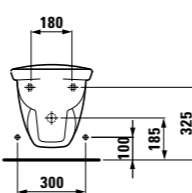
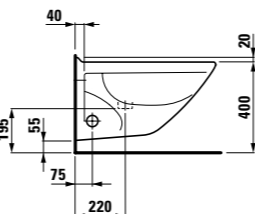

§3146.0
Wallhung bidet, with side opening
Wandbidet, mit Öffnung seitlich
Bidet suspendu, avec ouverture latérale
Bidet sospeso, con foro laterale

.000

moderna



§9346.0
Removable WC seat and cover, with anti-bacterial effect, stainless steel hinges
WC-Sitz mit Deckel, abnehmbar, mit antibakterieller Wirkung, Scharniere Edelstahl
Siège avec abattant, amovible, avec effet antibactérien, charnière en acier
Sedile copri water, estraibile, con effetto antibatterico, cerniere in acciaio inox

§9346.1
Removable WC seat and cover, with hydraulic lowering system and anti-bacterial effect, stainless steel hinges
WC-Sitz mit Deckel, abnehmbar, mit hydraulischer Absenkautomatik und antibakterieller Wirkung, Scharniere Edelstahl
Siège avec abattant, amovible, avec abaissement automatique hydraulique et effet antibactérien, charnière en acier
Sedile copri water, estraibile, con sistema di abbassamento idraulico e con effetto antibatterico, cerniere in acciaio inox







§9346.2
Removable WC seat and cover, with hydraulic lowering system and anti-bacterial effect, plastic hinges
WC-Sitz mit Deckel, abnehmbar, mit hydraulischer Absenkautomatik und antibakterieller Wirkung, Scharniere Kunststoff
Siège avec abattant, amovible, avec abaissement automatique hydraulique et effet antibactérien, charnière en plastique
Sedile copri water, estraibile, con sistema di abbassamento idraulico e con effetto antibatterico, cerniere in plastica

moderna



§9346.3
WC seat without cover, with anti-bacterial effect, stainless steel hinges
WC-Sitz ohne Deckel, mit antibakterieller Wirkung, Scharniere Edelstahl
Siège sans abattant, avec effet antibactérien, charnière en acier
Sedile copri water, con effetto antibatterico, cerniere in acciaio inox

Ceramic colours / Keramikfarben / Couleurs céramique / Colori della ceramica

-  .000 White / Weiss / Blanc / Bianco
-  .400 White / Weiss / Blanc / Bianco LCC (Laufen Clean Coat)
-  .018 Bahamabeige / Bahamabeige / Beige Bahama / Bahamabeige
-  .037 Manhattan / Manhattan / Manhattan / Manhattan
-  .046 Whisperblue / Whisperblue / Whisperblue / Whisperblue
-  .049 Pergamon / Pergamon / Pergamon / Pergamon
-  .050 Ägäis / Ägäis / Egée / Ägäis
-  .757 Edelweiss / Edelweiss / Edelweiss / Edelweiss



It is possible that not all products, sizes or colours are available in every country. Delivery periods may also differ in each case.

Unter Umständen sind nicht alle Produkte, Größen oder Farben in jedem Land verfügbar. Auch die jeweiligen Lieferzeiten können von Land zu Land abweichen.

Il se peut que les produits ne soient pas tous disponibles dans chaque pays dans toutes les dimensions et coloris. Les délais de livraisons peuvent également varier d'un pays à l'autre.

È possibile che non tutti i prodotti, le misure e i colori siano ugualmente disponibili in ogni Paese. Anche i tempi di consegna possono variare da un Paese all'altro.

The illustrated colours only approximately correspond to the actual shades. The bathroom layouts shown here are purely decorative and do not reflect all the technical requirements. The decorative parts used are not included in our commercial offer. We reserve the right to make technical changes without prior notice. Registered design.

Die Farbabbildungen entsprechen nur in etwa den tatsächlichen Farbtönen. Die hier gezeigten Badmilleus sind rein dekorativ und berücksichtigen nicht alle technischen Anforderungen. Unser Angebot beinhaltet nicht die verwendete Dekoration. Technische Änderungen sind vorbehalten. Design geschützt.

Les photos couleur ne correspondent que partiellement aux teintes effectives. Les ambiances reproduites ici sont simplement décoratives, les exigences techniques d'installation n'ont pas toujours été prises en compte. La décoration utilisée ne fait pas partie de notre offre commerciale. Sous réserve de modifications techniques. Modèle déposé.

I colori qui illustrati non corrispondono esattamente alle tonalità effettive. Gli ambienti qui riprodotti sono puramente decorativi e non tengono conto di tutte le specifiche tecniche. Gli articoli d'arredo usati non fanno parte della nostra offerta commerciale. Con riserva di apportare modifiche tecniche. Modello depositato.

Products with the Q-Plus certification comply with the European standard, as well as with the proven higher Swiss standard laid down by suissetec/VSA. LAUFEN ceramic products comply with this Swiss quality standard and are recommended accordingly.

Produkte mit der Q-Plus-Zertifizierung entsprechen einerseits der Europeanorm und andererseits zusätzlich dem bewährten, höheren Schweizer Standard, welcher durch die suissetec/VSA festgelegt wurde. LAUFEN Keramikprodukte entsprechen diesen schweizerischen Qualitätsmassstäben und haben die entsprechende Zulassungsempfehlung.

Les produits avec certification Q-Plus correspondent à la norme européenne et satisfont en plus aux standards suisses définis par la suissetec/VSA, encore plus élevés et qui ont largement fait leurs preuves. Les produits en céramique signés LAUFEN sont conformes à ces critères de qualité suisses et bénéficient donc des recommandations d'homologation correspondantes.

I prodotti con la certificazione Q-Plus sono conformi, da un lato, alla normativa europea e, dall'altro, anche allo standard svizzero, che prevede requisiti ancora più rigorosi, stabiliti dalla suissetec/VSA. I prodotti in ceramica LAUFEN rispettano questi criteri qualitativi svizzeri e dispongono della relativa certificazione di qualità.

Printed on certified paper from sustainably managed forests.

Gedruckt auf zertifiziertem Papier. Aus nachhaltig bewirtschafteten Wäldern.

Imprimé sur du papier certifié. Issu de forêts exploitées de façon durable.

Stampato su carta certificata. Proveniente da boschi a gestione sostenibile.

Product design	
Ceramics: Peter Wirz, Process Design	
Furniture: Marie Rahm und Monica Singer, Polka	
Faucets and mixers: Sven Adolph, Momentum Design	
Brochure	
Photos: Maurizio Marcato	
Styling: ps+a	
Graphics & concept: brenneisen communications	
Thanks to	
Bossi biancheria per abitare, Hewi, Magis, Martini Light, Mipa, Neo' di Rosanna Contadini, Sant' Agostino, Vetreria Vistosi	

Edition	02/2010
Ausgabe	02/2010
Edition	02/2010
Edizione	02/2010

Asia:
Roca Asia Ltd.
Room 2303, 23/F
148 Electric Road
North Point, Hong Kong
Tel. +852 250 624 38
Fax +852 250 624 92
laufenasia@hongkong.laufen.ch
www.laufen.com/export

Australia, New Zealand and Oceania:
Roca Group
Suite 304, Level 3
191 Clarence Street
Sydney, 2000
NSW, Australia
Tel. +61 (2) 9290 2331
Fax +61 (2) 9290 2786
josep.royo@roca.net
www.laufen.com

Austria:
LAUFEN Austria AG
Mariazeller Strasse 100
A-3150 Wilhelmsburg
Tel. +43 2746 6060
Fax +43 2746 6060 380
office@at.laufen.com
www.laufen.co.at

Benelux:
LAUFEN Benelux B.V.
Postbus 2702
NL-3800 GG Amersfoort
Tel. +31 (0)33 450 20 90
Fax +31 (0)33 450 20 91
info@laufen.nl
www.laufen.nl
www.laufen.be

Bulgaria:
Roca Bulgaria
Pirotska Street, 5
1421 Sofia/Bulgaria
Tel. +359 02 93 05 910
Fax +359 02 93 05 918
office.sofia@bg.roca.net
www.roca-bulgaria.bg

China:
Roca Sanitary Trading
(Shanghai) co. Ltd
Room 503-505, City Gateway
No. 396 North Caoxi Road
Shanghai 200030, China
Tel. +86 21 3368 8822
Fax +86 21 3368 8299
enquiries@roca.net.cn
www.roca.cn

Croatia, Serbia, Bosnia, Herzegovina:
LAUFEN CZ s.r.o.
Jagodno 102
10415 Novo Čiče
Hrvatska
Tel./Fax +385 1 619 56 76
office.zagreb@hr.laufen.com
www.laufen.com/hr

Czech Republic:
LAUFEN CZ s.r.o.
V Tűnich 3/1637
120 00 Praha 2
Tel. +420 296 337 711
Fax +420 296 337 713
marketing@cz.laufen.com
www.laufen.com/cz

Estonia, Latvia:
LAUFEN CZ s.r.o.
Pae 25-8
Tallinn, 11414
Estonia
Tel./Fax +372 6 215 569
office.tallinn@ee.laufen.com
www.laufen.com

France:
LAUFEN France
19-21, rue de Bretagne
Z.I. des Béthunes
F-95310 St-Ouen-L'Aumône Cedex
Tel. +33 1 34 40 39 31
Fax +33 1 30 37 02 65
commercial@laufen-france.com
www.laufen.com/fr

Germany:
Roca GmbH
Vertrieb LAUFEN
Feincheswiese 17
56424 Staudt
Tel. +49 26 02 / 94 93 33
Fax +49 26 02 / 94 93 355
info.staudt@de.laufen.com
www.laufen.com/de

Hungary:
LAUFEN CZ s.r.o.
Ördögárok u. 121
H-1029 Budapest
Magyarország
Tel. +36 1 376 96 24
Fax +36 1 376 96 24
office.budapest@hu.laufen.com
www.laufen.com

Italy:
LAUFEN Italia s.r.l.
Via Leonardo da Vinci, 24
I-20080 Casarile (MI)
Tel. +39 02 900 25 88
Fax +39 02 905 21 74
www.laufen.it

Lithuania:
LAUFEN CZ s.r.o.
Užupio g. 30
Vilnius, 01203
Lietuva
Tel. +370 5 215 30 76
Fax +370 5 215 30 86
office.vilnius@lt.laufen.com
www.laufen.com/lt

Morocco:
Roca Maroc, S.A.
route de Marrakech, km 2,5
BP 571, 26000 Settat
Tel. +212 23 40 59 41
Fax +212 23 40 59 42
www.roca.ma

Nordic:
Laufen Nordic ApS
Fejovej 8
DK-4652 Haarlev
Tel. +45 56 287 87
Fax +45 56 287 237
info@dk.laufen.com
www.laufen.com/export

Poland:
Roca Polska Sp. z o.o.
ul. Wyczółkowskiego 20
44-109 Gliwice
Tel. +48 32 339 41 00
Fax +48 32 339 41 01
biuro@roca.pl
www.laufen.com

Portugal:
Roca, S.A., Portugal
Apartado 575, Ponte da Madalena
2416-905 - Leiria, Portugal
Tel. +351 244 720 000
Fax +351 244 722 373
marketing.le@pt.roca.net
www.laufen.pt

Romania:
LAUFEN CZ s.r.o.
Str. Matei Basarab nr. 82
500008 Brasov
Tel./Fax +40 268 413 609
Mobil: +40 749 075 174
office.bucharest@ro.laufen.com

Russia:
Roca Santekhnika
Promyshlennaya Str. 7, Tosno
Leningrad region, 187000, Russia
Tel. +7 812 347 94 49
Fax +7 812 347 94 50
office.moscow@ru.laufen.com
www.laufen.ru

Roca Santekhnika
Altufievskoye shosse, 1/7
Moscow, 127106, Russia
Tel. +7 (495) 956 33 30
Tel. +7 (495) 230 65 48
Fax +7 (495) 234 07 97
office.moscow@ru.laufen.com
www.laufen.ru

Slovakia:
LAUFEN SK s.r.o.
Štefanovičova 12
811 04 Bratislava
Tel. +421 2 526 210 24
Fax +421 2 526 210 25
office.bratislava@sk.laufen.com
www.laufen.com/sk

Slovenia, Montenegro, Macedonia, Albania, Moldova:
LAUFEN CZ s.r.o.
Ul. Ivana Regenta 2
SI-6310 IZOLA, Slovenia
Tel. +386(0)5 640 12 12
Mob. +386(0)31 342 567
Fax +386(0)5 640 12 12
office.ljubljana@si.laufen.com

Spain:
LAUFEN
Av Diagonal 513
08029 Barcelona
Tel. +34 93 366 12 00
Fax +34 93 430 20 19
infosan@roca.es
www.laufen.es

Switzerland:
Keramik Laufen AG
Wahlenstrasse 46
CH-4242 Laufen
Tel. +41 61 765 75 75
Fax +41 61 766 56 53
forum@laufen.ch
www.laufen.ch

Similor AG
Wahlenstrasse 46
CH-4242 Laufen
Customer Service 0848 000 166
Tel. +41 61 765 73 33
Fax +41 61 765 73 34
info@similorgroup.com
www.similorgroup.com

Ukraine:
LAUFEN CZ s.r.o. Ukraine
Kiev 04128
19, Ak. Tupoleva str., office „Laufen“
Tel. +380 44 499 0620
Fax +380 44 499 0621
office.kiev@ua.laufen.com
www.laufen.net.ua

United Kingdom and Ireland:
LAUFEN Ltd.
c/o Roca Ltd.
Samson Road
Hermitage Industrial Estate
Coalville
Leicestershire
LE67 3FP
Tel. +44 (0)1530 510007
Fax +44 (0)1530 838949
info@uk.laufen.com
www.laufen.co.uk

Export:
LAUFEN Bathrooms AG
Wahlenstrasse 46
CH-4242 Laufen
Tel. +41 61 765 76 09
Fax +41 61 761 10 20
export@laufen.ch
www.laufen.com/export

Headquarters:
LAUFEN Bathrooms AG
Wahlenstrasse 46
CH-4242 Laufen
Tel. +41 61 765 71 11
Fax +41 61 761 36 60
feedback@laufen.ch
www.laufen.com